



(11) **EP 2 107 151 B1**

(12) **EUROPEAN PATENT SPECIFICATION**

(45) Date of publication and mention of the grant of the patent:
11.06.2014 Bulletin 2014/24

(51) Int Cl.:
D06F 37/20^(2006.01)

(21) Application number: **08153788.8**

(22) Date of filing: **31.03.2008**

(54) **Method for estimating the moment of inertia of the rotating unit of a washing machine, and washing machine implementing said method**

Verfahren zum Einschätzen des Trägheitsmoments einer Dreheinheit einer Waschmaschine und Waschmaschine, die dieses Verfahren umsetzt

Procédé d'évaluation du moment d'inertie de l'unité rotative d'une machine à laver, et machine à laver mettant en oeuvre ce procédé

(84) Designated Contracting States:
AT BE BG CH CY CZ DE DK EE ES FI FR GB GR HR HU IE IS IT LI LT LU LV MC MT NL NO PL PT RO SE SI SK TR

- **Giroto, Terenzio**
33080 Porcia (IT)
- **Giovagnoni, Marco**
33100 Udine (IT)

(43) Date of publication of application:
07.10.2009 Bulletin 2009/41

(74) Representative: **Nardoni, Andrea et al**
Electrolux Italia S.p.A.
Corso Lino Zanussi, 30
33080 Porcia (PN) (IT)

(73) Proprietor: **Electrolux Home Products Corporation N.V.**
1130 Brussel (BE)

(56) References cited:
EP-A- 1 447 469 EP-A- 1 609 901

(72) Inventors:

- **Altinier, Fabio**
33080 Porcia (IT)

EP 2 107 151 B1

Note: Within nine months of the publication of the mention of the grant of the European patent in the European Patent Bulletin, any person may give notice to the European Patent Office of opposition to that patent, in accordance with the Implementing Regulations. Notice of opposition shall not be deemed to have been filed until the opposition fee has been paid. (Art. 99(1) European Patent Convention).

Description

[0001] The present invention relates to a method for estimating the moment of inertia of the rotating unit of a washing machine, and to a washing machine implementing said method.

[0002] In particular, the present invention relates to a method that is able to estimate the moment of inertia in a washing machine or in a washing-and-drying machine of the type comprising: a box-like frame, and a washing unit set within the frame and comprising a tub fixed within the frame by means of a suspension equipment and a rotating unit, which is, in turn, provided with a laundry drum housed in an axially rotatable way within the tub, and a driving device able to set the laundry drum in rotation about its longitudinal axis inside the tub itself.

[0003] Methods are known that are able to determine the unbalancing of the washing unit of a washing machine in order to control the speed of rotation of the laundry drum so as to prevent possible conditions of collision of the washing unit with the frame and at the same time reduce vibrations and/or phenomena of bouncing of the washing machine caused by said unbalancing.

[0004] Some of the aforesaid methods determine the unbalancing of the washing unit through calculation of the moment of inertia of the "total rotating load" associated to the mass of the rotating unit plus the mass of the laundry housed inside the laundry drum.

[0005] In particular, the aforesaid methods calculate the moment of inertia via an energy-balance function, which necessarily requires both a measurement of the torque and a measurement of the speed of rotation of the laundry drum in a condition of "stability" of the rotating unit, which is reached only when, thanks to the centrifugal force, the laundry is substantially stuck to the internal wall of the laundry drum in a state of immobility.

[0006] If the energy-balance function used in the aforesaid methods on the one hand enables precise calculation of the moment of inertia of the rotating unit plus the laundry contained in the drum, on the other hand it is constrained to a condition of "stability" of the rotating unit being reached, which occurs when the speed of rotation of the washing drum reaches the so-called "sticking speed", which, as is known, is the minimum speed of rotation of the drum at which the laundry remains completely stuck to the wall of the drum.

[0007] The sticking speed referred to above can reach relatively high values and consequently, in the case of non-uniform distribution of the laundry inside the drum, can determine an uncontrolled unbalancing of the rotating unit so causing a collision of the washing unit with the frame.

[0008] There consequently exists, on the one hand, the need to eliminate the risk of collision of the washing unit with the frame in any condition of operation of the washing machine and, on the other hand, the need to have available an estimate of the moment of inertia of the rotating unit plus laundry present in the laundry drum even when the speed of rotation is maintained around small values, i.e., lower than the sticking speed.

[0009] EP 1 447 469 discloses a method for determining the loading of the drum of a laundry-treatment machine by establishing the moment of mass inertia of the drum, which is loaded with laundry, from the electrical power consumption of the drive motor for the drum which rotates at different rotation speeds above the resting rotation speed.

[0010] The aim of the present invention is consequently to provide a method that will be able to estimate the moment of inertia even at speeds lower than the aforesaid sticking speed in such a way as to be able to maintain control of unbalancing at any speed, hence eliminating any condition of collision between the washing unit and the frame of the washing machine.

[0011] According to the present invention, a method for estimating the moment of inertia of the rotating unit of a washing machine is consequently proposed, as specified in Claim 1 and preferably, but not necessarily, in any one of the claims depending either directly or indirectly upon Claim 1.

[0012] According to the present invention, a device for estimating the moment of inertia of the rotating unit of a washing machine is moreover provided as specified in Claim 9 and preferably, but not necessarily, in any one of the claims depending either directly or indirectly upon Claim 9.

[0013] The present invention will now be described with reference to the annexed drawings, which illustrate a non-limiting example of embodiment thereof and in which:

- Figure 1 illustrates in perspective view, with parts in cross section and parts removed for clarity, a washing machine provided according to the teachings of the present invention;
- Figure 2 is a schematic view of a flowchart indicating the operations implemented by the method for estimating the moment of inertia of the washing machine illustrated in Figure 1;
- Figures 3 is a schematic illustration of the device for estimating the moment of inertia of the rotating unit plus laundry present in the laundry drum, in the washing machine shown in Figure 1; and - Figures 4 illustrates an example of detection of the torque provided to the rotating unit over a pre-set speed profile of rotation imposed to the drum of the washing machine.

[0014] With reference to Figure 1, number 1 designates as a whole a washing machine or a washing-and-drying

machine for house-hold use, which basically comprises: an outer box-like frame 2; and a washing unit 3 connected to the frame 2 through suspension devices 3a and damping devices 3b, and in turn comprising a laundry drum 4, which is designed to house the laundry B to be washed and is mounted within the box-like frame 2 so that it is free to rotate about an axis of rotation A of its own, and is set directly facing an opening for loading and unloading the laundry made in the frame 2.

[0015] The electrical household appliance 1 further comprises a motor unit, such as, for example, an electric motor 5, which is connected to the laundry drum 4 through a drive member 6 for transmitting the motion for driving the laundry drum 4 in rotation about its axis of rotation A.

[0016] The laundry drum 4, the drive member 6, and the rotor of the electric motor 5 together define a rotating unit 7 of the washing machine 1.

[0017] The washing machine 1 further comprises a control unit 8, designed to govern the electric motor 5, and a calculation device 9, which is designed to estimate the total moment of inertia J_e of the rotating unit 7 plus the laundry contained inside the drum 4.

[0018] In the case in point, in the example shown in Figure 3, the calculation device 9 comprises a memory module 10, stored inside which is a series of linear parameters $K_i(\omega_i)$ (described in detail hereinafter), and an estimator module 11, which receives at input the torque values $T_i(\omega_i)$ provided to the rotating unit 7 by the motor 5, and supplies at output the moment of inertia J_e determined as a function of the torque values $T_i(\omega_i)$ itself.

[0019] In detail, the estimator module 11 calculates the moment of inertia J_e through a linear combination $FL(K_i(\omega_i), T_i(\omega_i))$ comprising one or more torque values $T_i(\omega_i)$ multiplied by respective pre-set linear parameters $K_i(\omega_i)$, and in which each torque value $T_i(\omega_i)$ is measured at a pre-set speed ω_i lower than a sticking speed ω_a .

[0020] In particular, in the example illustrated in Figure 3, the moment of inertia J_e is calculated through a linear combination $FL(K_i(\omega_i), T_i(\omega_i)) = \sum K_i(\omega_i) * T_i(\omega_i)$ comprising preferably, but not necessarily seven linear parameters and six torque values T_i determined at six respective different speeds ω_i preferably, but not necessarily alternated in opposite directions:

$$J_e = FL(K_i(\omega_i), T_i(\omega_i));$$

i.e.

$$J_e = K_0 + K_1(\omega_1) * T_1(\omega_1) + K_2(\omega_2) * T_2(\omega_2) + K_3(\omega_3) * T_3(\omega_3) + K_4(\omega_4) * T_4(\omega_4) + K_5(\omega_5) * T_5(\omega_5) + K_6(\omega_6) * T_6(\omega_6)$$

[0021] The linear parameters $K_i(\omega_i)$ can be estimated experimentally through laboratory tests in which there are measured the real inertia and the torque values T_i provided to the rotating unit 7 in pre-set conditions of speed ω_i . The calibration of the parameters is done collecting data with different laundry loads (starting from the minimum up to the maximum load) and performing several test cycles with the specific speed profile selected for the machine under analysis. In the case in point, it is possible to determine the linear parameters $K_i(\omega_i)$ through an estimation method, preferably, but not necessarily, the least-squares method. The least-squares method is a known optimization technique, which enables a linear combination of specific functions to be found that, by means of linear parameters, approaches as closely as possible an interpolation of a set of data, which, in this case, are constituted by the torque values $T_i(\omega_i)$ measured at the various speeds ω_i .

[0022] With reference to Figures 2 and 4, the method for estimating the total moment of inertia J_e of the rotating unit 7 plus the laundry B contained inside the laundry drum 4 will be described in what follows.

[0023] It should be pointed out that the present invention is related to a low speed measuring procedure to evaluate an approximated value of the inertia without reaching the sticking speed. A speed profile used for the inertia estimation is showed in the figure 4. The profile is composed of some steps at different speeds that are preferably, but not necessarily performed in a different direction (in the figure there are six steps at constant speed, three CW and three CCW). Over each step at low speed the total motor torque is carried out. The total motor torque is mainly the contribution of two terms: the friction torque T_a (approximately constant) and the lifting torque T_s (the portion required to lift the freely moving part of the laundry load). The lifting torque T_s is related to the laundry amount: larger is the laundry load and higher is the lifting torque T_s at a specific speed. Therefore, an appropriate combination of the torque values coming from each step provides a good approximation of the inertia of the rotating unit plus the laundry present in the laundry drum. The number of steps and speeds involved in the procedure could be preferably, but not necessarily different for machines with different washing units. Generally, more steps mean higher precision in the inertia estimation. Generally the torque

values are measured with clothes completely wet but the procedure can be useful also for measuring the inertia when the clothes are still dry.

[0024] With reference to Figures 2 and 4 in the initial step, the speed of the drum 4 reaches a pre-set value $\omega=\omega_1$, and a counter i and the moment of inertia J_e are initialized by setting $i=1$ and $J_e=0$, respectively (block 100).

[0025] In this step, the calculation device 9 measures the total torque $T_1(\omega_1)$ (block 110), and then (block 120) the temporary value of the moment of inertia J_e is updated by adding the value $K_1(\omega_1)*T_1(\omega_1)$, thus implementing the following relation:

$$J_e = J_e + K_1(\omega_1) * T_1(\omega_1)$$

At this point, a check is made to see whether the counter i has reached its maximum value N_{max} ($i=N_{max}$) (block 130), corresponding to the maximum number of terms envisaged by the linear combination $FL(K_i, T_i(\omega_i))$ and, if it has not reached said value (output NO from block 130), the counter is incremented ($i=i+1$) and at the same time the speed is varied, i.e., $\omega=\omega_i$ (block 140).

[0026] Once the speed $\omega=\omega_i$ is reached, the method envisages measuring the total torque $T_i(\omega)$ (block 110), and then (block 120) updating again the temporary value J_e by adding the value $K_i(\omega_i)*T_i(\omega_i)$ via the relation:

$$J_e = J_e + K_i(\omega_i) * T_i(\omega_i)$$

If, instead, the counter has reached its maximum value $i=N_{max}$ (output YES from block 130), the method provides the final value of the moment of inertia J_e by adding the pre-set constant K_0 correlated to the friction torque of the rotating unit 7.

[0027] The method explained above estimates therefore the moment of inertia J_e by measuring the torque values T_i provided by the motor over some steps performed at substantially constant speed for a certain time interval.

[0028] In general, the method for estimating the moment of inertia J_e measures and elaborates the torque values T_i provided to the rotating unit and drives the motor 5 in such a way to generate a stepwise pattern of pre-determined speeds, or else a ramp of speed.

[0029] It should moreover be pointed out that the measurements of torque can be performed by rotating the drum alternately in opposite directions at pre-set speeds ω_i , as shown in the example of Figure 4.

[0030] It should moreover be pointed out that, in the case where the sticking speed ω_a has a value higher than approximately 75 rpm, the pre-set measurement speeds ω_i of the aforesaid method can be conveniently comprised in a range of approximately 45-70 rpm.

[0031] The calculation device 9 further comprises an estimation module 12, which receives at input the moment of inertia J_e and supplies at output an estimate of the weight of the laundry B contained in the drum. In the case in point, the estimation module 12 can implement a function $P=G(J_e)$, determined, for example at an experimental stage, which enables unique determination, for each value of the moment of inertia J_e , of a corresponding weight P of the laundry contained in the drum 4. Said function can correspond, for example, to a curve (not indicated) obtained experimentally via laboratory tests indicating the evolution of the moment of inertia J_e as the weight P of the laundry B varies.

[0032] Estimation of the moment of inertia J_e is performed on the basis of the measurement of a series of torques T_i , the main component of which is the lifting torque T_s .

[0033] As above disclosed the aforesaid estimation of the moment of inertia J_e is substantially based upon the fact that, in conditions of low speed, i.e., lower than the sticking speed ω_a , the measured torque T_i basically comprises two components, i.e., the lifting torque T_s deriving from the action of lifting of the laundry, which, since it is not stuck to the wall, tends to shift by gravity towards the bottom part of the drum 4, and a friction torque T_a correlated to the friction encountered by the rotating unit 7.

[0034] Laboratory tests have, in fact, shown that at low speeds, i.e., in conditions of non-sticking of the laundry, the lifting torque T_s has a relevant effect in comparison with the friction torque.

[0035] In the case in point, laboratory tests have shown that, if a mass present inside the drum is completely stuck into over the pre-set speed profile (for example when the drum speed is higher than the sticking speed or when some fixed masses is used for simulating an increase in the drum inertia), the aforesaid method estimates a moment of inertia J_e substantially constant even if the load varies.

In this case, in fact, the contribution of the lifting torque on the torque T_i measured is substantially zero in so far as the laundry is completely stuck to the internal wall of the drum 4. Consequently, the torque applied corresponds to the one necessary to overcome the friction torque of the rotating unit and the inertia estimation procedure doesn't work properly.

[0036] The device described above presents the advantage of being extremely simple to produce and hence of being

particularly inexpensive.

[0037] In addition, the method is able to estimate the moment of inertia of the rotating unit and the weight of the laundry B even at low speeds hence enabling a timely evaluation of the unbalancing before the sticking speed is reached. In this way, any condition of unbalancing of the washing unit that may cause collision of the washing unit with the frame is consequently conveniently eliminated.

[0038] Finally, it is clear that modifications and variations may be made to the calculation device, the method, and the washing machine described above, without thereby departing from the scope of the present invention, as defined by the annexed claims.

Claims

1. A method for estimating the moment of inertia (J_E) of the rotating unit (7) of a washing or washing-and-drying machine (1); said machine (1) comprising a frame (2) and a washing unit (3) connected to the frame (2) and comprising said rotating unit (7), which is, in turn, provided with a drum (4), which is able to house the laundry (B) and is mounted within the frame (2) so that it is free to rotate about an axis of rotation (A) of its own, and with driving means (5, 6) designed to set said drum (4) in rotation about said axis (A); said method being **characterized in that** it comprises the steps of:

a) establishing one or more linear parameters ($K_i(\omega_i)$), each of which is associated to a corresponding pre-set speed (ω_i) of rotation of said drum (4), which has a value lower than a sticking-speed threshold (ω_a) corresponding to a minimum speed at which the laundry remains completely stuck to the internal wall of said drum (4) so as to form with the drum (4) itself a single body;

b) rotating said drum (4) containing the laundry (B) in such a way as to reach at least one of said pre-set speeds (ω_i) of rotation;

c) for each said pre-set speed (ω_i) of rotation, detecting the value of the total torque (T_i) provided to the rotating unit (7) plus the laundry (B) contained in the drum (4);

d) estimating the total moment of inertia (J_E) of the rotating unit (7) plus the laundry contained in the corresponding drum (4) through a linear combination of said torques (T_i), detected at each said pre-set speed (ω_i) of rotation, and by using the said linear parameters (K_i) associated to the pre-set speed (ω_i) of rotation itself.

2. The method according to Claim 1, wherein said linear parameter (K_i) corresponds to a numeric value correlated to the moment of inertia (J_E) and to the torque (T_i) of the rotating unit (7) in a condition in which the drum (4) rotates at said pre-set speed (ω_i) of rotation.

3. The method according to Claim 1 or Claim 2, wherein said linear parameter (K_i) corresponds to a numeric value correlated to the ratio between the moment of inertia (J_E) and the torque (T_i) of the rotating unit (7) in a condition in which said drum (4) rotates at said pre-set speed (ω_i) of rotation.

4. The method according to any one of the preceding claims, wherein said linear combination for the calculation of said moments of inertia (J_E) does not comprise the speed (ω_i) of rotation of said drum (4).

5. The method according to any one of the preceding claims, wherein said linear combination comprises the following relation:

$$J_E = \sum_{i=1}^N K_i(\omega_i) \cdot T_i(\omega_i)$$

where $K_i(\omega_i)$ and $T_i(\omega_i)$ are, respectively, the linear parameters and the torques detected at the pre-set speeds (ω_i) of rotation.

6. The method according to any one of the preceding claims, wherein said step b) comprises the step of rotating said drum (4) according to a substantially staircase speed profile, in which each step of the staircase corresponds to a respective pre-set speed (ω_i) of rotation.

7. The method according to any one of Claims 1 to 6, wherein said step b) comprises the step of rotating said drum

(4) according to a substantially continuous ramp speed profile.

8. The method according to any one of the preceding claims, comprising the step of estimating the weight of the laundry (B) contained in said drum (4) as a function of said moment of inertia (Je).

9. A washing or washing-and-drying machine comprising a frame (2) and a washing unit (3) connected to the frame (2) and comprising said rotating unit (7), which is, in turn, provided with a drum (4), which is designed to house the laundry and is mounted within the frame (2) so that it is free to rotate about an axis of rotation (A) of its own, and driving means (5, 6) designed to set said drum (4) in rotation about said axis (A); said machine being **characterized in that** it comprises a device (9) for estimating the moment of inertia (Je) of said rotating unit (7); said device comprising:

- memory means (10) containing one or more linear parameters ($K_i(\omega_i)$), each of which is associated to a corresponding pre-set speed (ω_i) of rotation of said drum (4) having a value lower than a sticking-speed threshold (ω_a) corresponding to a minimum speed at which the laundry remains completely stuck to the internal wall of said drum (4) so as to form with the drum (4) itself a single body;
- control means designed to rotate said drum (4) containing the laundry in such a way as to reach at least one of said pre-set speeds (ω_i) of rotation;
- detection means designed to detect, for each said pre-set speed (ω_i) of rotation, the value of the total torque (T_i) provided to the rotating unit (7) plus the laundry contained in the drum (4);
- calculation means (11) designed to implement a linear combination of said torques (T_i) by using the said linear parameters (K_i) for estimating the total moment of inertia (Je) of the rotating unit (7) plus the laundry contained in the corresponding drum (4).

10. Machine according to Claim 9, wherein said linear parameter (K_i) corresponds to a numeric value correlated to the moment of inertia (Je) and to the torque (T_i) of the rotating unit (7) in a condition in which said drum (4) rotates at said pre-set speed (ω_i) of rotation.

11. Machine according to Claim 9 or Claim 10, wherein said linear parameter (K_i) corresponds to a numeric value correlated to the ratio between the moment of inertia (Je) and the torque (T_i) of the rotating unit (7) in a condition in which said drum (4) rotates at said pre-set speed (ω_i) of rotation.

12. Machine according to any one of Claims 9 to 11, wherein said linear combination for the calculation of said moments of inertia (Je) does not comprise the speed (ω_i) of rotation of said drum (4).

13. Machine according to any one of Claims 9 to 12, wherein said linear combination comprises the following relation:

$$J_E = \sum_{i=1}^N K_i(\omega_i) \cdot T_i(\omega_i)$$

where $K_i(\omega_i)$ and $T_i(\omega_i)$ are, respectively, the linear parameters and the torques detected at the pre-set speeds (ω_i) of rotation.

14. Machine according to any one of Claims 9 to 13, wherein said control means are designed to control rotation of said drum (4) according to a substantially staircase speed profile, in which each step of the staircase corresponds to a respective pre-set speed (ω_i) of rotation.

15. Machine according to any one of Claims 9 to 14, wherein said control means are designed to control rotation of said drum (4) according to a substantially continuous ramp speed profile.

16. Machine according to any one of Claims 9 to 15, wherein said device (9) comprises means (12) designed to estimate the weight of the laundry (B) contained in said drum as a function of the moment of inertia (Je).

Patentansprüche

1. Verfahren zum Einschätzen des Trägheitsmoments (J_E) der Dreheinheit (7) einer Waschmaschine oder einer Waschtrockner-Maschine (1), wobei die Maschine (1) einen Rahmen (2) und eine mit dem Rahmen (2) verbundene Wascheinheit (3) und die Dreheinheit (7) umfasst, die wiederum mit einer Trommel (4) versehen ist, die in der Lage ist, die Wäsche (B) aufzunehmen, und im Rahmen (2) befestigt ist, sodass sie sich frei um eine eigene Drehachse (A) drehen kann, und mit Antriebsmitteln (5, 6), die ausgelegt sind, die Trommel (4) in eine Drehung um die Achse (A) zu versetzen, wobei das Verfahren **dadurch gekennzeichnet ist, dass** es folgende Schritte umfasst:
- 5
- 10 a) Erstellen eines oder mehrerer linearer Parameter ($K_i(\omega_i)$), wobei jeder mit einer entsprechenden voreingestellten Drehzahl (ω_i) der Trommel (4) im Zusammenhang steht, die einen niedrigeren Wert als ein klebender Drehzahlschwellenwert (ω_a) hat, der einer minimalen Drehzahl entspricht, bei der die Wäsche vollkommen an der Innenwand der Trommel (4) kleben bleibt, sodass ein einzelner Körper mit der Trommel (4) selbst gebildet wird;
- 15 b) Drehen der Trommel (4), die die Wäsche (B) enthält, auf solche Weise, dass zumindest eine der voreingestellten Drehzahlen (ω_i) erreicht wird;
- c) Detektieren des Werts des Gesamtdrehmoments (T_i), das auf die Dreheinheit (7) mit der in der Trommel (4) enthaltenen Wäsche (B) aufgebracht wird, für jede voreingestellte Drehzahl (ω_i);
- 20 d) Einschätzen des Gesamtträgheitsmoments (J_E) der Dreheinheit (7) mit der in der entsprechenden Trommel (4) enthaltenen Wäsche durch eine lineare Kombination der Drehmomente (T_i), detektiert bei jeder voreingestellten Drehzahl (ω_i), und durch das Verwenden der linearen Parameter (K_i), die mit der voreingestellten Drehzahl (ω_i) selbst im Zusammenhang stehen.
2. Verfahren nach Anspruch 1, wobei der lineare Parameter (K_i) einem numerischen Wert entspricht, der mit dem Trägheitsmoment (J_E) und dem Drehmoment (T_i) der Dreheinheit (7) in einem Zustand korreliert, in dem sich die Trommel (4) mit der voreingestellten Drehzahl (ω_i) dreht.
- 25
3. Verfahren nach Anspruch 1 oder Anspruch 2, wobei der lineare Parameter (K_i) einem numerischen Wert entspricht, der mit dem Verhältnis zwischen dem Trägheitsmoment (J_E) und dem Drehmoment (T_i) der Dreheinheit (7) in einem Zustand korreliert, in dem sich die Trommel (4) mit der voreingestellten Drehzahl (ω_i) dreht.
- 30
4. Verfahren nach einem der vorhergehenden Ansprüche, wobei die lineare Kombination für die Berechnung der Trägheitsmomente (J_E) die Drehzahl (ω_i) der Trommel (4) nicht umfasst.
- 35
5. Verfahren nach einem der vorhergehenden Ansprüche, wobei die lineare Kombination die folgende Beziehung umfasst:
- 40
- $$J_E = \sum_{i=1}^N K_i(\omega_i) \cdot T_i(\omega_i)$$
- wobei $K_i(\omega_i)$ bzw. $T_i(\omega_i)$ die linearen Parameter bzw. die Drehmomente sind, die bei den voreingestellten Drehzahlen (ω_i) detektiert werden.
- 45
6. Verfahren nach einem der vorhergehenden Ansprüche, wobei der Schritt b) den Schritt des Drehens der Trommel (4) gemäß einem im Wesentlichen treppenförmigen Drehzahlprofil umfasst, wobei jede Stufe der Treppe einer jeweiligen voreingestellten Drehzahl (ω_i) entspricht.
- 50
7. Verfahren nach einem der Ansprüche 1 bis 6, wobei der Schritt b) den Schritt des Drehens der Trommel (4) gemäß einem im Wesentlichen durchgängigen Rampen-Drehzahlprofil umfasst.
8. Verfahren nach einem der vorhergehenden Ansprüche, umfassend den Schritt des Einschätzens des Gewichts der in der Trommel (4) enthaltenen Wäsche (B) als Funktion des Trägheitsmoments (J_E).
- 55
9. Waschmaschine oder Waschtrockner-Maschine, umfassend einen Rahmen (2) und eine mit dem Rahmen (2) verbundene Wascheinheit (3) und die Dreheinheit (7), die wiederum mit einer Trommel (4) versehen ist, die ausgelegt ist, die Wäsche aufzunehmen, und im Rahmen (2) befestigt ist, sodass sie sich frei um eine eigene Drehachse (A)

EP 2 107 151 B1

drehen kann, und mit Antriebsmitteln (5, 6), die ausgelegt sind, die Trommel (4) in eine Drehung um die Achse (A) zu versetzen, wobei die Maschine **dadurch gekennzeichnet ist, dass** sie eine Vorrichtung (9) zum Einschätzen des Trägheitsmoments (J_e) der Dreheinheit (7) umfasst, wobei die Vorrichtung Folgendes umfasst:

- 5
- Speichermittel (10), die einen oder mehrere lineare Parameter ($K_i(\omega_i)$) enthalten, wobei jeder mit einer entsprechenden voreingestellten Drehzahl (ω_i) der Trommel (4) im Zusammenhang steht, die einen niedrigeren Wert als ein klebender Drehzahlschwellenwert (ω_a) hat, der einer minimalen Drehzahl entspricht, bei der die Wäsche vollkommen an der Innenwand der Trommel (4) kleben bleibt, sodass ein einzelner Körper mit der Trommel (4) selbst gebildet wird;

10

 - Steuermittel, die zum Drehen der Trommel (4), die die Wäsche enthält, auf solche Weise, dass zumindest eine der voreingestellten Drehzahlen (ω_i) erreicht wird, ausgelegt sind;
 - Detektionsmittel, die zum Detektieren des Werts des Gesamtdrehmoments (T_i), das auf die Dreheinheit (7) mit der in der Trommel (4) enthaltenen Wäsche aufgebracht wird, für jede voreingestellte Drehzahl (ω_i) ausgelegt sind;

15

 - Berechnungsmittel (11), die zum Umsetzen einer linearen Kombination der Drehmomente (T_i) durch das Verwenden der linearen Parameter (K_i) zum Einschätzen des Gesamtträgheitsmoments (J_e) der Dreheinheit (7) mit der in der entsprechenden Trommel (4) enthaltenen Wäsche ausgelegt sind.

20 **10.** Maschine nach Anspruch 9, wobei der lineare Parameter (K_i) einem numerischen Wert entspricht, der mit dem Trägheitsmoment (J_e) und dem Drehmoment (T_i) der Dreheinheit (7) in einem Zustand korreliert, in dem sich die Trommel (4) mit der voreingestellten Drehzahl (ω_i) dreht.

25 **11.** Maschine nach Anspruch 9 oder Anspruch 10, wobei der lineare Parameter (K_i) einem numerischen Wert entspricht, der mit dem Verhältnis zwischen dem Trägheitsmoment (J_e) und dem Drehmoment (T_i) der Dreheinheit (7) in einem Zustand korreliert, in dem sich die Trommel (4) mit der voreingestellten Drehzahl (ω_i) dreht.

12. Maschine nach einem der Ansprüche 9 bis 11, wobei die lineare Kombination für die Berechnung der Trägheitsmomente (J_e) die Drehzahl (ω_i) der Trommel (4) nicht umfasst.

30 **13.** Maschine nach einem der Ansprüche 9 bis 12, wobei die lineare Kombination die folgende Beziehung umfasst:

$$J_E = \sum_{i=1}^N K_i(\omega_i) \cdot T_i(\omega_i)$$

35 wobei $K_i(\omega_i)$ bzw. $T_i(\omega_i)$ die linearen Parameter bzw. die Drehmomente sind, die bei den voreingestellten Drehzahlen (ω_i) detektiert werden.

40 **14.** Maschine nach einem der Ansprüche 9 bis 13, wobei die Steuermittel ausgelegt sind, die Drehung der Trommel (4) gemäß einem im Wesentlichen treppenförmigen Drehzahlprofil zu steuern, wobei jede Stufe der Treppe einer jeweiligen voreingestellten Drehzahl (ω_i) entspricht.

45 **15.** Maschine nach einem der Ansprüche 9 bis 14, wobei die Steuermittel ausgelegt sind, die Drehung der Trommel (4) gemäß einem im Wesentlichen durchgängigen Rampen-Drehzahlprofil zu steuern.

16. Maschine nach einem der Ansprüche 9 bis 15, wobei die Vorrichtung (9) Mittel (12) umfasst, die ausgelegt sind, das Gewicht der in der Trommel enthaltenen Wäsche (B) als Funktion des Trägheitsmoments (J_e) einzuschätzen.

50 **Revendications**

1. Procédé d'évaluation du moment d'inertie (J_e) de l'unité rotative (7) d'une machine à laver ou d'un lave-linge sèche-linge (1) ; ladite machine (1) comprenant un châssis (2) et une unité de lavage (3) reliée au châssis (2) et comprenant ladite unité rotative (7), qui, à son tour, comporte un tambour (4), qui est apte à recevoir le linge (B) et est monté à l'intérieur du châssis (2) de telle sorte qu'il est libre de tourner autour d'un axe de rotation (A) de lui-même, et des moyens d'entraînement (5, 6) conçus pour entraîner ledit tambour (4) en rotation autour dudit axe (A) ; ledit procédé étant **caractérisé par le fait qu'il** comprend les étapes consistant à :

55

EP 2 107 151 B1

- a) établir un ou plusieurs paramètres linéaires ($K_i(\omega_i)$), chacun desquels étant associé à une vitesse de rotation préétablie (ω_i) correspondante dudit tambour (4), qui a une valeur inférieure à un seuil de vitesse d'adhérence (ω_a) correspondant à une vitesse minimale à laquelle le linge demeure complètement collé à la paroi interne dudit tambour (4) de façon à former avec le tambour (4) lui-même un seul corps ;
- b) faire tourner ledit tambour (4) contenant le linge (B) de telle manière à atteindre au moins l'une desdites vitesses de rotation préétablies (ω_i) ;
- c) pour chaque vitesse de rotation préétablie (ω_i) précitée, détecter la valeur du couple total (T_i) fourni à l'unité rotative (7) plus le linge (B) contenu dans le tambour (4) ;
- d) évaluer le moment d'inertie total (J_e) de l'unité rotative (7) plus le linge contenu dans le tambour (4) correspondant par une combinaison linéaire desdits couples (T_i), détectés à chaque vitesse de rotation préétablie (ω_i) précitée, et par utilisation desdits paramètres linéaires (K_i) associés à la vitesse de rotation préétablie (ω_i) elle-même.
2. Procédé selon la revendication 1, dans lequel ledit paramètre linéaire (K_i) correspond à une valeur numérique corrélée au moment d'inertie (J_e) et au couple (T_i) de l'unité rotative (7) dans un état dans lequel le tambour (4) tourne à ladite vitesse de rotation préétablie (ω_i).
3. Procédé selon l'une des revendications 1 ou 2, dans lequel ledit paramètre linéaire (K_i) correspond à une valeur numérique corrélée au rapport entre le moment d'inertie (J_e) et le couple (T_i) de l'unité rotative (7) dans un état dans lequel ledit tambour (4) tourne à ladite vitesse de rotation préétablie (ω_i).
4. Procédé selon l'une quelconque des revendications précédentes, dans lequel ladite combinaison linéaire pour le calcul desdits moments d'inertie (J_e) ne comprend pas la vitesse de rotation (ω_i) dudit tambour (4).
5. Procédé selon l'une quelconque des revendications précédentes, dans lequel ladite combinaison linéaire comprend la relation suivante :

$$J_E = \sum_{i=1}^N K_i(\omega_i) \cdot T_i(\omega_i)$$

- $K_i(\omega_i)$ et $T_i(\omega_i)$ étant, respectivement, les paramètres linéaires et les couples détectés aux vitesses de rotation préétablies (ω_i).
6. Procédé selon l'une quelconque des revendications précédentes, dans lequel ladite étape b) comprend l'étape de rotation dudit tambour (4) selon un profil de vitesse sensiblement en escalier, dans lequel chaque marche de l'escalier correspond à une vitesse de rotation préétablie (ω_i) respective.
7. Procédé selon l'une quelconque des revendications 1 à 6, dans lequel ladite étape b) comprend l'étape de rotation dudit tambour (4) selon un profil de vitesse en rampe sensiblement continue.
8. Procédé selon l'une quelconque des revendications précédentes, comprenant l'étape d'évaluation du poids du linge (B) contenu dans ledit tambour (4) en fonction dudit moment d'inertie (J_e).
9. Machine à laver ou lave-linge sèche-linge comprenant un châssis (2) et une unité de lavage (3) reliée au châssis (2) et comprenant ladite unité rotative (7), qui, à son tour, comporte un tambour (4), qui est conçu pour recevoir le linge et est monté à l'intérieur du châssis (2) de telle sorte qu'il est libre de tourner autour d'un axe de rotation (A) de lui-même, et des moyens d'entraînement (5, 6) conçus pour entraîner ledit tambour (4) en rotation autour dudit axe (A) ; ladite machine étant **caractérisée par le fait qu'elle** comprend un dispositif (9) d'évaluation du moment d'inertie (J_e) de ladite unité rotative (7) ; ledit dispositif comprenant :
- des moyens de mémoire (10) contenant un ou plusieurs paramètres linéaires ($K_i(\omega_i)$), chacun desquels étant associé à une vitesse de rotation préétablie (ω_i) correspondante dudit tambour (4) ayant une valeur inférieure à un seuil de vitesse d'adhérence (ω_a) correspondant à une vitesse minimale à laquelle le linge demeure complètement collé à la paroi interne dudit tambour (4) de façon à former avec le tambour (4) lui-même un seul corps ;
 - des moyens de commande conçus pour faire tourner ledit tambour (4) contenant le linge de telle manière à

EP 2 107 151 B1

atteindre au moins l'une desdites vitesses de rotation préréglées (ω_i) ;

- des moyens de détection conçus pour détecter, pour chaque vitesse de rotation préréglée (ω_i) précitée, la valeur du couple total (T_i) fourni à l'unité rotative (7) plus le linge contenu dans le tambour (4) ;

- des moyens de calcul (11) conçus pour effectuer une combinaison linéaire desdits couples (T_i) par utilisation desdits paramètres linéaires (K_i) pour évaluer le moment d'inertie total (J_e) de l'unité rotative (7) plus le linge contenu dans le tambour (4) correspondant.

10. Machine selon la revendication 9, dans laquelle ledit paramètre linéaire (K_i) correspond à une valeur numérique corrélée au moment d'inertie (J_e) et au couple (T_i) de l'unité rotative (7) dans un état dans lequel ledit tambour (4) tourne à ladite vitesse de rotation préréglée (ω_i).

11. Machine selon l'une des revendications 9 ou 10, dans laquelle ledit paramètre linéaire (K_i) correspond à une valeur numérique corrélée au rapport entre le moment d'inertie (J_e) et le couple (T_i) de l'unité rotative (7) dans un état dans lequel ledit tambour (4) tourne à ladite vitesse de rotation préréglée (ω_i).

12. Machine selon l'une quelconque des revendications 9 à 11, dans laquelle ladite combinaison linéaire pour le calcul desdits moments d'inertie (J_e) ne comprend pas la vitesse de rotation (ω_i) dudit tambour (4).

13. Machine selon l'une quelconque des revendications 9 à 12, dans laquelle ladite combinaison linéaire comprend la relation suivante :

$$J_E = \sum_{i=1}^N K_i(\omega_i) \cdot T_i(\omega_i)$$

$K_i(\omega_i)$ et $T_i(\omega_i)$ étant, respectivement, les paramètres linéaires et les couples détectés aux vitesses de rotation préréglées (ω_i).

14. Machine selon l'une quelconque des revendications 9 à 13, dans laquelle lesdits moyens de commande sont conçus pour commander la rotation dudit tambour (4) selon un profil de vitesse sensiblement en escalier, dans lequel chaque marche de l'escalier correspond à une vitesse de rotation préréglée (ω_i) respective.

15. Machine selon l'une quelconque des revendications 9 à 14, dans laquelle lesdits moyens de commande sont conçus pour commander la rotation dudit tambour (4) selon un profil de vitesse en rampe sensiblement continue.

16. Machine selon l'une quelconque des revendications 9 à 15, dans laquelle ledit dispositif (9) comprend des moyens (12) conçus pour évaluer le poids du linge (B) contenu dans ledit tambour en fonction du moment d'inertie (J_e).

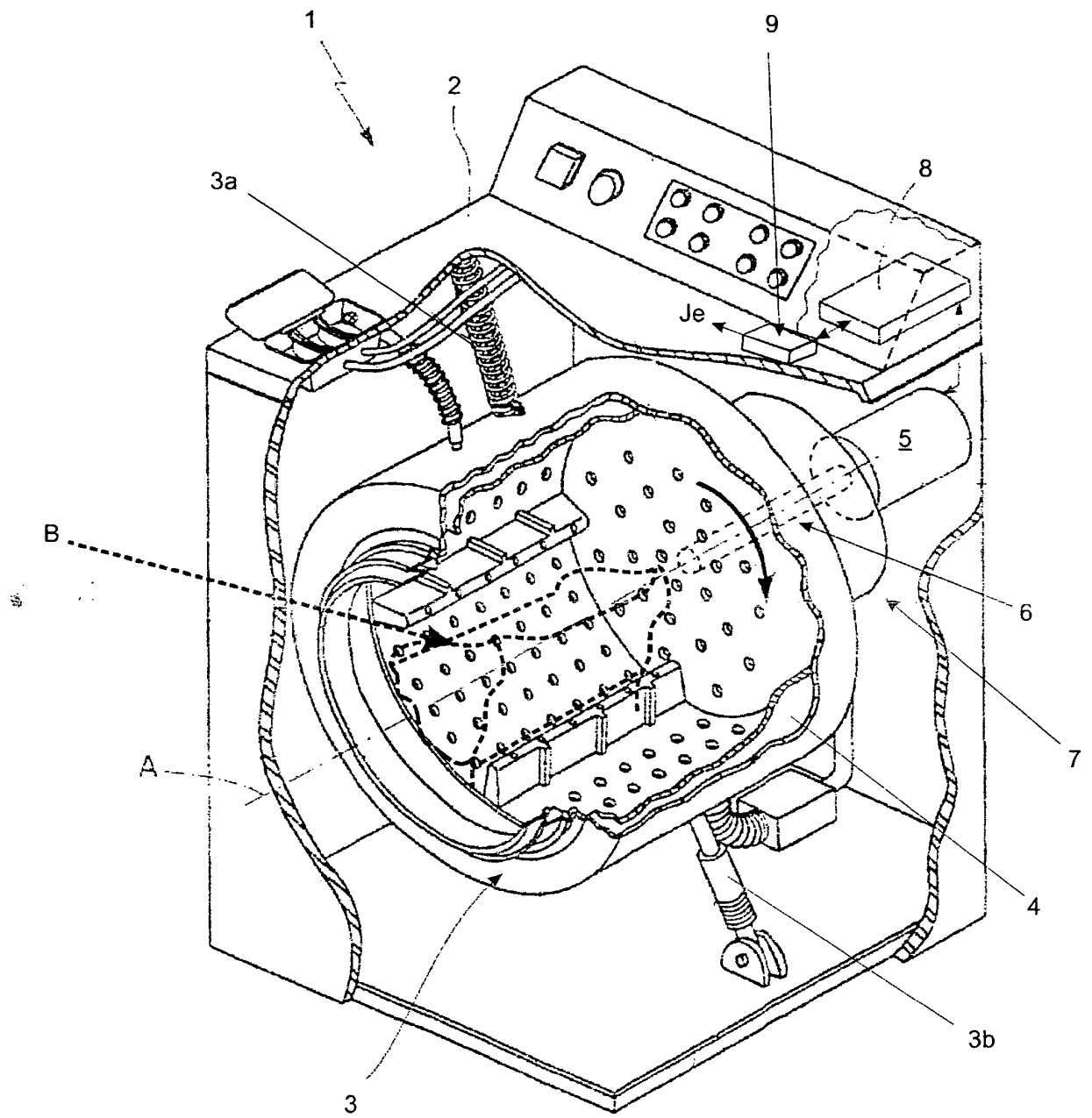

Fig. 1

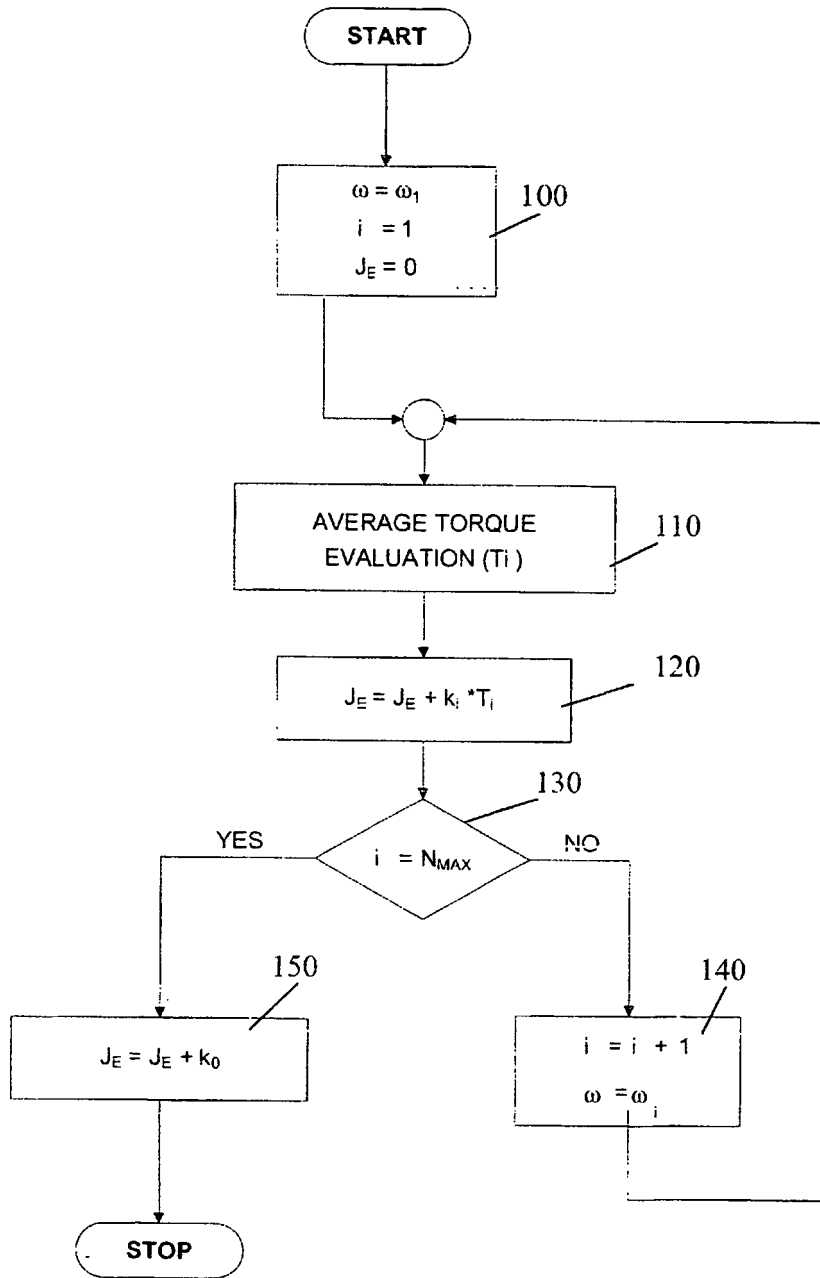

Fig. 2

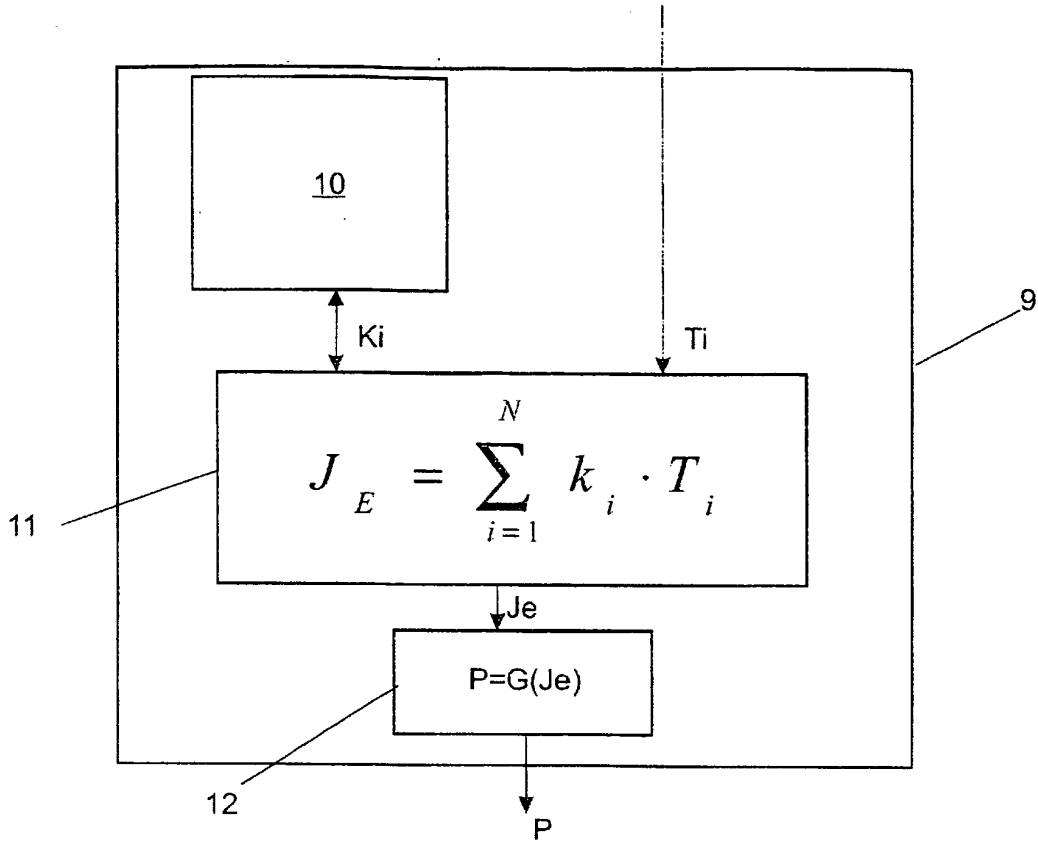

Fig. 3

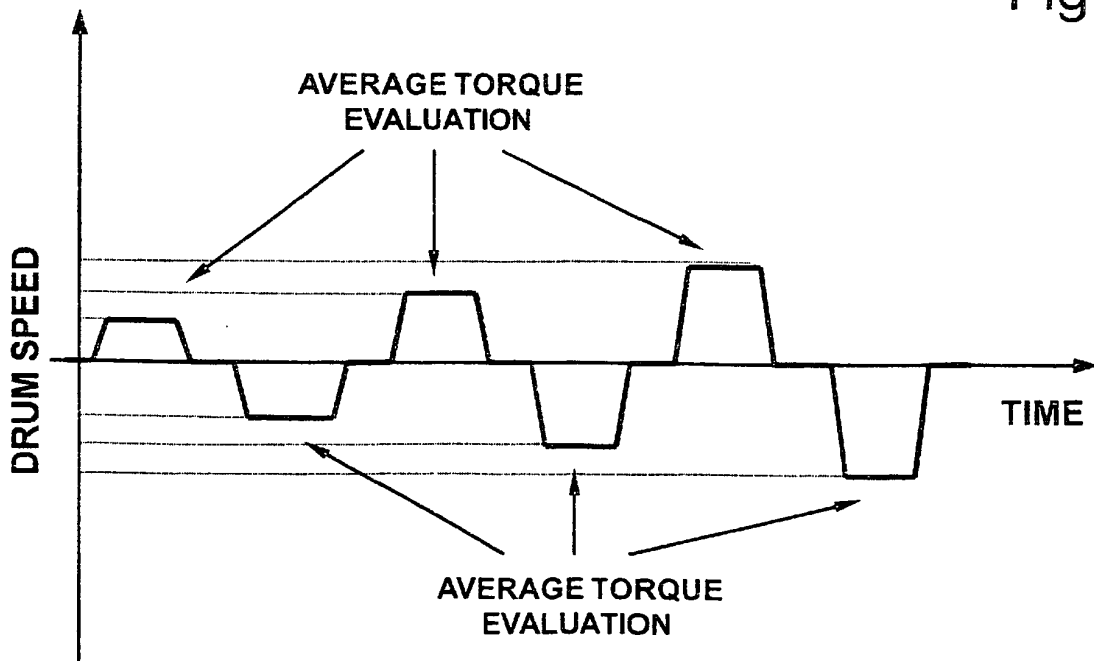

Fig. 4

REFERENCES CITED IN THE DESCRIPTION

This list of references cited by the applicant is for the reader's convenience only. It does not form part of the European patent document. Even though great care has been taken in compiling the references, errors or omissions cannot be excluded and the EPO disclaims all liability in this regard.

Patent documents cited in the description

- EP 1447469 A [0009]