

A Preliminary report of recording the Stella 1 Roman River Barge, Italy

Filipe Castro

105 Anthropology Building, Texas A&M University, College Station, TX 77843-4352, USA

Massimo Capulli

Università degli Studi di Udine, Vicolo Florio 2/B-33100 Udine, Italy

The remains of a Roman barge were found in 1981 in the River Stella, Udine, Italy. Its cargo consisted mainly of roof tiles. It was excavated in 1998 and 1999, and detailed recording of the hull, and a second wooden structure, was achieved in 2011. A spread of material upstream of the wreck has been investigated 2012–2015. The barge was originally dated to the first quarter of the 1st century AD by the *in situ* cargo. This article describes the bottom-based sewn-plank hull construction and examines it in the light of local boatbuilding traditions. The second wooden structure is also described, along with recent finds and new dating evidence from the dispersed material. The Stella 1 excavation was part of the Anaxum Project, a wider study of the Stella River's cultural landscape through time.

© 2016 The Authors

Key words: Anaxum Project, river barge, Roman, bottom-based, sewn-plank construction, *imbrices*, *tegulae*.

The Stella River, called Anaxum in antiquity (Pliny, NH, III, 126), runs through a rich maritime landscape. It rises not far from the base of the Alps, and flows into the Marano Lagoon, connecting a varied and long-inhabited landscape to the sea (Fig. 1). It is crossed by the *Via Annia*, a Roman road built in the 2nd century BC, and its economic importance is attested throughout its rich recorded

history (Capulli, 2013). The Anaxum Project began as a partnership between the Department of History and Cultural Heritage of University of Udine and Superintendence of Cultural Heritage of Friuli-Venezia Giulia, and is an ongoing study of the Stella River cultural landscape through time (Capulli, 2010; Bartoli *et al.*, 2012; Capulli *et al.*, 2013; Capulli, 2014a, 2014b; Capulli and Castro, 2014).



Figure 1. Localization (Image © 2010 Google, Mapdata © 2010 Google).

The Stella-Anaxum River runs through a landscape characterized by an aquifer strip, known as the ‘spring belt’, dividing the Friuli plain into ‘upper’ and ‘lower’ parts. This strip is created by the percolation of both rain water and water from the Alpine rivers through the permeable soils. The groundwater moves very slowly from the mountains to the valley, following the natural slope of the terrain. In the middle of the plain the layer of gravel thins, and the groundwater encounters almost-impermeable clay that forces it upwards into the ‘spring belt’. Here water gushes spontaneously out of the ground to form pools of clear drinkable water, often rich in minerals and at a temperature of 12–14°C. The vegetation in this area is diverse, from dry meadows to water-meadows with a marsh-type vegetation and aquatic plants.

The Stella-Anaxum is the most important resurgence river of this region and has a constant water-flow rate throughout the year. This waterway has influenced human settlement, as shown by the abundant archaeological remains and current structures, which include villages, roads, rural architecture, mansions, castles, mills, farms, historical buildings, and underwater archaeological sites along its length.

Within the scope of the Anaxum Project, the remains of a small Roman barge, initially dated to the first quarter of the 1st century AD (Vitri *et al.*, 2003: 330),

were studied by a joint team from the universities of Udine and Texas A&M. The barge, designated Stella 1, had been found in 1981 in the Stella River, at Palazzolo dello Stella, 600 m from the Piazza del Porto in the village of Precenicco, Udine, Italy. (M.C.)

The Stella 1 river barge

Long barges are characteristic of river transport since at least the Classical period, and the Stella 1 boat is a good example of this type of watercraft. As Eric Rieth has put it, these boats cannot be imagined abstracted from their landscapes (Rieth, 1998: 7–24). They sailed close to the banks, often carrying heavy loads—in this case local ceramics—along relatively short pendular routes up and down rivers. Relatively poor and simple when compared to some contemporary oceangoing ships, long barges were nevertheless important economic assets that transported people, animals, goods, and ideas much faster and requiring far less energy than any form of transport on land.

The Stella 1 barge was built within a construction tradition particular to this region (Table 1). Recorded examples of laced vessels span a period of well over a millennium from the pre-Roman boat currently being excavated at Zambratija, Croatia (Uhač and

Table 1. Summary of known sewn-plank boats in the region

Designation	Date	Location	Publications
Zambratija	Pre-Roman	Bay of Zambratija, Pula, Croatia	Uhač., 2009; Uhač and Uhač, 2012
Barena del Vigno Nin 1 and 2	6th–5th cent. BC Early Roman	Venice lagoon, Italy Adriatic harbour of Enona, Croatia	Dorigo, 1983 Brusić and Domjan, 1985
Cavanella d’Adige Commachio	2nd–1st cent. BC 1st cent. BC	North-east Italy North central Italy	Tiboni, 2009 Berti, 1990
Corte Cavanella 1 Marcon-Altino	1st–2nd cent. AD Roman	North-east Italy North-east Italy	Sanesi <i>et al.</i> , 1986 Cipriano, 2011
Meolo San Francesco del Deserto	Roman Roman	North-east Italy San Francesco island, Venice lagoon, Italy	Beltrame, C., 2002 Capulli and Pellegrini, 2010
Concordia Sagittaria	Roman	North-east Italy	Unpublished report
Lipe	1st cent. AD	Ljubljana, Slovenia	Boetto and Rouse, 2011
Lido 1	1st cent. AD	S. Nicoletto, Venice, Italy	Beltrame, 1996
Aquileia 1	1st cent. AD	Canale Anfora, Aquileia, Italy	Bertacchi, 1990
Lido 2	1st–2nd cent. AD	Alberoni, Lido, Venice, Italy	Beltrame, 2002
Corte Cavanella 2	1st–2nd cent. AD	North-east Italy	Sanesi <i>et al.</i> , 1986
Caska	1st–2nd cent. AD	Pag, Croatia	Radic, Rossi I. and Boetto, G., 2010
Aquileia 2	2nd–3rd cent. AD	Canale Anfora, Aquileia, Italy	Beltrame and Gaddi, 2013
Lido 3	1st cent. BC–1st cent. AD	Ospedale Lido, Venice, Italy	Willis and Capulli, 2014
Largo Europa	2nd cent. AD	Padova, Italy	Balista <i>et al.</i> , 1993
Oderzo	2nd cent. AD	North-east Italy	Trovò, R., 1996
Cervia	2th–4th cent. AD	North central Italy	Bonino, 1968
Santa Maria in Padovetere	5nd cent. AD	Comacchio, North central Italy	Beltrame and Costa, (ISBSA 14, Gdansk 2015)
Pomposa	11th cent. AD	North central Italy	Bonino, 1968

Uhač, 2012), to the medieval barge of Pomposa, in the Po River (Bonino, 1968, 1978). Unfortunately, few are fully published and a comprehensive study is impossible at this point because the information available is incomplete and sometimes confusing. Laced vessels have been found in the upper Adriatic region, both on the coast and along its rivers, for more than a century. The sizes range from the 30 m-long barge from Ljubljana (Boetto and Rousse, 2011), or the c.23 m-long vessel from Commachio (Berti, 1990), to the presumed small Nin boats (Brusić and Domjan, 1985). Giulia Boetto has proposed the best working taxonomy (Boetto and Rousse, 2012), and Carlo Beltrame has published the most comprehensive inventory of laced boats found in the Adriatic region (Beltrame, 2002, 2013), but enough detailed images and measurements are not available to allow any meaningful, in-depth study. To our knowledge no complete list has been published so far, and many of the finds are not definitively dated (Table 1). Most of the vessels in this laced tradition have flat bottoms assembled first by lacing the planks together over a grass wad that is compressed against the inboard seams and acts as caulking. On the interior face of the planking, the lacing holes are widened with a triangular notch, which facilitates the insertion of wedges to lock each stitch in place. The bottom structure is then reinforced with treenailed floor-timbers, and the side planks bent against a number of futtocks, which can be extensions of L-shaped floor-timbers, or fastened to the floor-timbers with treenails.

In 1998 and 1999 campaigns were carried out to assess the site, recover the cargo, and record the hull. A one-week campaign was carried out by IDRA s.n.c. in 1998, under the scientific direction of Serena Vitri from the Soprintendenza per I Beni Archeologici del Friuli-Venezia Giulia with fieldwork directed by Francesca Bressan (Vitri *et al.*, 2003). The team concentrated its efforts on the *in situ* cargo inside the vessel. It consisted mainly of roof tiles, both *imbrices* and *tegulae*, which were stacked vertically on the flat bottom of the barge. The ceramics were extremely fragile, partly due to the action of a red algae (*hildenbrandia rivularis*) that had infested most of the ceramics on the site. Some 120 *imbrices* were recovered, of which 17 were marked with the names of six different manufacturers: M. Albius Macrus, M. Albius Rufus, L. Epidius Theodorus, C. Oppius Agathopus, C. Titius Hermeros and Valeria Magna Epidiana, and date to the 1st century AD. Manufacturer's marks are important because they may help date and provenience the ceramic materials. With the exception of *C. Oppius Agathopus*, which comes from Concordia Sagittaria (a town about 20 km from the site), the other names refer to local producers: the villages of Pocenja and Teor on the Stella river. However, these products were spread throughout the upper Adriatic Sea, from Dalmatia in Croatia to the Marche region in central Italy, and demonstrate the

importance of the ceramics produced in this area (Gomez, 1996). The presence of Lamboglia 2 and Dressel 2–4 amphoras was also attested. The maker's marks and amphora typologies establish a date for the cargo in the first half of the 1st century AD.

All the finds were stored in the museum of the Stella River, located 600 m downstream of the site. In November 1998, however, the lower levels of this building were flooded and part of the artefact collection destroyed or left without labels (Vitri *et al.*, 2003). The remaining artefact collection is now curated and deposited in the Aquileia Museum.

In 1999 a second campaign, lasting two weeks, aimed at recording the hull remains, again under the scientific direction of Vitri and directed by Bressan (Vitri *et al.*, 2003). Both the hull and a wooden structure found nearby were recorded then covered with several layers of geotextile and sand bags, and left *in situ*. The quality of the work undertaken by IDRA Company was excellent, especially when we consider the diving conditions and the short amount of time available for recording. Several publications followed the excavation reports, including a detailed analysis of the cargo (Vitri *et al.*, 1999, Vitri *et al.*, 2003).

In 2011, during a single six-week season, a joint team from the universities of Udine and Texas A&M, sponsored by ProMare Foundation and Texas A&M University Center for Maritime Archaeology and Conservation, conducted a third campaign on the site, under the scientific supervision of Luigi Fozzati, Soprintendenza Archeologia del Friuli-Venezia Giulia. The aim was to obtain a complete record of the Stella 1, including removing the ceiling to examine the concealed hull structure and frame sequence (Fozzati *et al.*, 2012). Moreover, a trench was dug under the barge to allow a thorough observation of the hull's outboard. The geotextile protection placed at the end of the 1999 campaign was removed and the hull found in a state of preservation consistent with the 1990s description. The sediment protecting the hull remains was removed and the site recorded before the ceiling, which lay unfixed over the frames, was removed. A layer of silt with a heavy concentration of leaves and twigs was then removed, exposing the framing system and bottom planks, which were subsequently recorded.

A second timber structure found in 1999 near the hull was exposed and recorded as well, after which the entire site was again covered with geotextile and protected with sand bags.

From 2013 to present, the Anaxum Project has continued research focused on an area of dispersed artefacts, situated upstream, north of the Stella 1 hull remains. The area surveyed is 8–10 m wide and extends 80 m upstream and the assemblage is composed mostly of building materials, such as *imbrices*, *tegulae* and bricks, in part similar to those recovered during the 1990s campaign. The aim is to quantify the material that the vessel (or possibly vessels) was carrying. (M.C.)

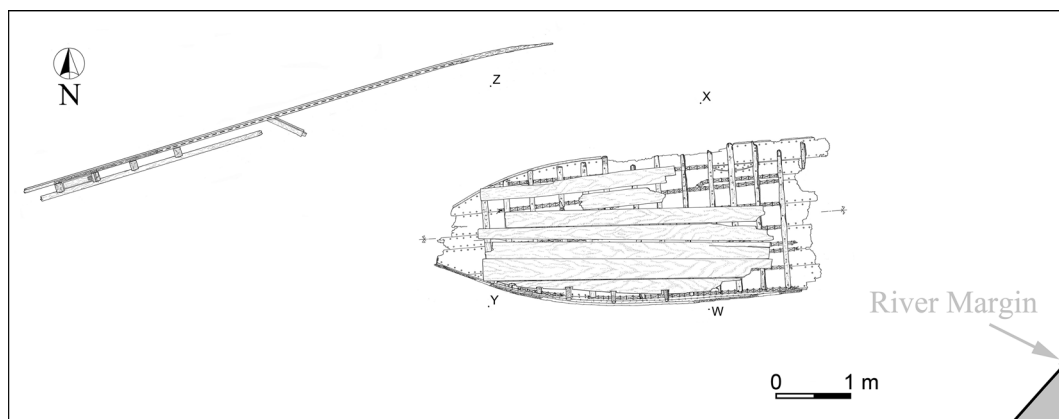

Figure 2. Site plan. (Filipe Castro and Kotaro Yamafune)

Methodology

In 2011, the hull was unwrapped, cleaned, and retagged, and remapped using metric tapes, a series of fixed points, and a goniometer, to trilaterate all the materials found, recorded and raised. Sketches, drawings, photographs, and video were used to produce an accurate map of the area surveyed and excavated. ProMare's collaboration enabled the use of *Site Surveyor*[®], a GIS-based software that allows trilateration and positioning of artefacts, which was extremely useful to position the shipwreck and the structure.

Within the dispersion area all artefacts are drawn in situ and labelled using a 2 × 2 m grid. Once on the surface, the artefacts are rinsed, sorted, and weighed by grid square. (M.C.)

Hull description

The hull remains lie on the left margin of the river, almost perfectly oriented E-W, at an angle of around 45° to the axis of the river (Fig. 2). The bottom is slightly inclined towards the centre of the river and tilted to upstream, lying at a depth between 4.6 and 5.6 m. Several trenches opened around the hull to a level of sterile hard sand c.0.25 m below the bottom of the boat showed that the hull rests in a layer of sand of variable thickness of 50–100 mm around the shipwreck and inside, over the ceiling planking, which was backfilled in the 1990s before being covered with geotextile. Outside the hull this sand layer is mixed with large timber fragments, twigs and leaves. This layer of sand and organic material covers a thicker layer, of c.250 mm, of brown to grey silt, with a heavy concentration of twigs and leaves, which was also found underneath the boat's ceiling planking. This brown and grey silt in turn stands on a thick and heavily compacted layer of grey clay that exfoliates along thin horizontal layers. Underneath this layer there is a layer of highly compacted sand without much apparent organic material.

The Stella 1 boat is a flat-bottomed barge, its bottom is a little over 2 m wide at the level of frame O4, and has a surviving length of c.4.90 m. Neither the bow nor stern were conserved, although the convergence of the sides on the west extremity of the hull suggests the proximity of one of the ends. The depth in hold is also unknown, but the preserved futtocks and the height of the imbrices stacked over the ceiling, which are about 0.60 m tall, suggest a typical barge shape, long and low. It is possible that the sides of the Stella 1 boat stood 0.70–0.80 m high, making an angle around 75 degrees to the horizontal and thus requiring a draught of around 0.25 m when loaded with a single layer of the imbrices found inside it. This estimated draught was calculated considering that the imbrices weigh about 11.5 kg each and are 0.60 m long, 0.45 m wide, and 0.07 m thick. They take about 0.09 m of space when stacked as a result of irregularities in their fabrication. Within a 1 m-long section of the hull it was thus possible to stack 2.08 rows of 20 imbrices each, weighing $41.6 \times 11.5 \text{ kg} = 478.4 \text{ kg}$. This weight corresponds to the barge displacement for a draught of approximately 0.24 m.

The wood was badly decayed, extremely fragile, and this circumstance badly impacted the excavation and recording processes. Samples taken in 1999 indicated that this boat's planking was built with oak (*Quercus* sp.) and elm (*Ulmus* sp.), and the ceiling with spruce planks (*Picea abies*). No samples were taken for species identification in 2011, but all the frames seemed to have been cut from spruce as well (*Picea abies*). Some of the futtocks—in particular O10S—may have been cut from oak. All these trees are native to the region (Vitri *et al.*, 2003: 336). (F.C.)

Planking

Planks were numbered from F1 to F7 ('F' for *fasciame*, in the original reports) and repairs from R1 to R7. The outer surface of planking was eroded in many places, thus the preserved plank thicknesses varied between 24 and 36 mm (Table 2). Where the outer surface was

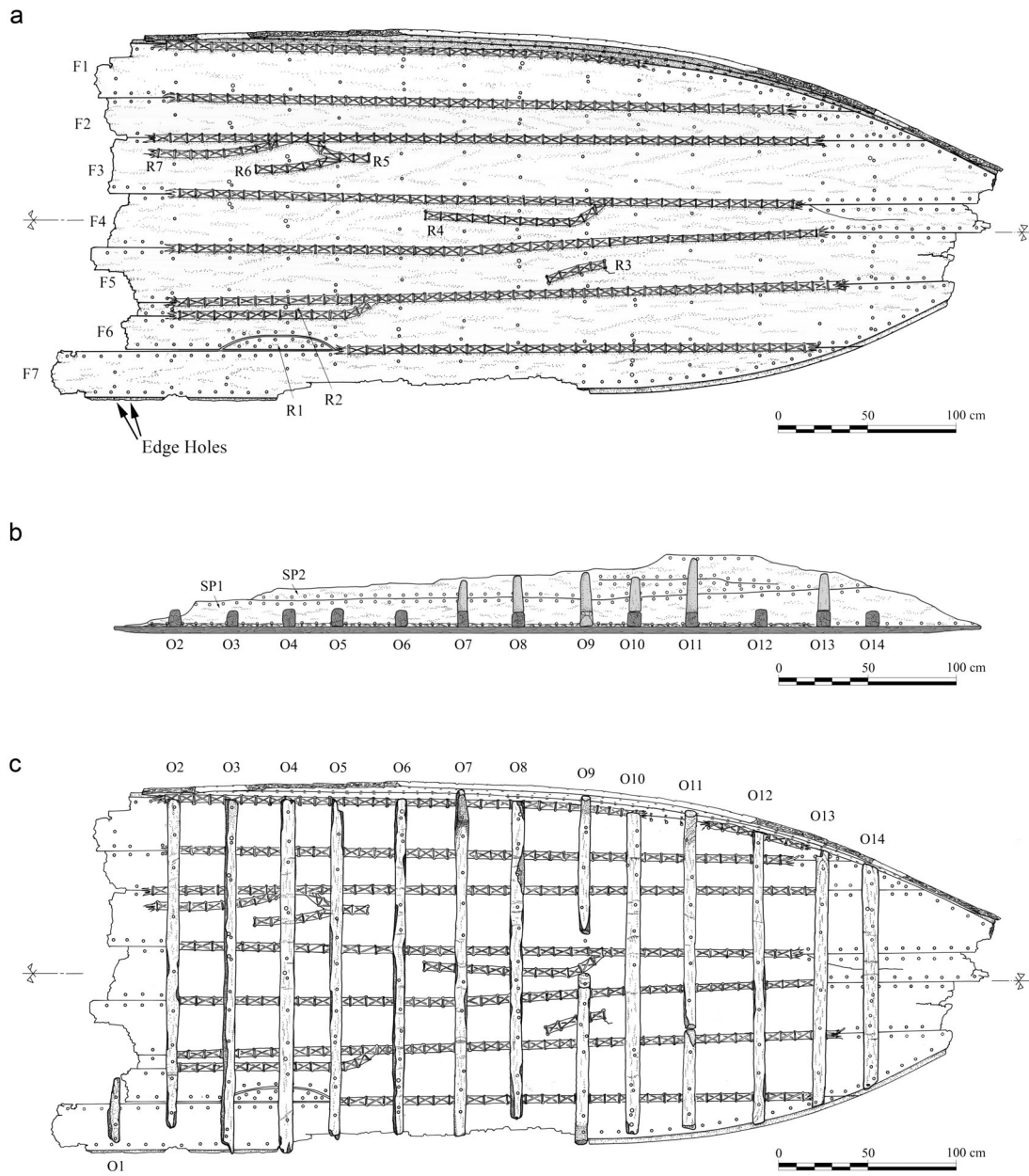

Figure 3. a) Hypothetical view of the planking plan of the Stella 1 shipwreck without the floor timbers, which were not removed; b) longitudinal view with side planks 1 and 2; c) surviving frames of the Stella 1 wreck: plan. (Filipe Castro and Kotaro Yamafune)

preserved, however, its thickness was invariably 36 mm. Both sides of the planks presented saw marks.

Planking is laced together, along straight lines, following a known pattern used in the upper Adriatic region. Where weaknesses in the planking were perceived, or where repairs were needed during the lifespan of this boat, small patches were introduced (Fig. 3a). Due to low visibility, the non-intrusive nature of this project, and time and budget constraints, it was not possible to ascertain the order in which these

patches were laced, or if they were introduced during or after the boat's construction. The interior surface of the bottom was painted with a thick layer of a hard varnish that made it difficult to analyse the lacing sequence in detail, but the lacing around the patches seemed to have been remade at the time they were placed: all seams were well planned and executed, and there were no patches clearly inserted over the existing lacing. Floor-timber O9, however, was cut in the middle to allow one repair. Even under floor-timber O9, the lacing runs

Table 2. *Dimensions of the hull planking*

Plank	Preserved length (m)	Width at east (m)	Width at west (m)
F1	4.33	0.33	0
R1	0.63	0.08	–
F2	4.63	0.23	0.19
R2	1.33	0.10	–
F3	5.00	0.32	0.39
F4	5.01	0.32	0.17
F5	4.88	0.31	0.29
F6	4.73	0.28	0.36
F7	4.60	0.28	0

in a perfectly well-organized pattern, with no trace of mistakes or improvised fixes. Lacing was also used to keep cracks in the planks from leaking. In several places cracks were closed with lacing that runs alongside with the seams and ends where the cracks end.

Despite the cracks and repairs, the bottom planks seemed to have been sawn from large logs of reasonably good quality (Fig. 4). The overall impression is that the planking was carefully chosen: there were few knots and the grain ran regularly along the surviving length of each plank.

Two side planks were preserved on the south side of the shipwreck, to a maximum height of 0.40 m (Fig. 3b). Both were 36 mm thick. The lower plank (SP1) was 4.86 m long and its width varied from 120 to 220 mm. The upper plank (SP2) is damaged along the top edge, preserved along 3.53 m and is 230 mm at its widest section. The seam between them was not a perfectly straight line.

On the north side of the shipwreck no side planks were preserved, but bottom plank F7 presented two small dowel holes with diameters near 8 mm, spaced around 40 mm, which may have been used to reinforce the connection between the bottom and the side of the vessel at the turn of the bilge (Fig. 5). Such edge fastenings are not generally considered part of the local Roman boatbuilding tradition, but have been found in a plank found not far away from the Stella 1 site, on the Aquileia 2005 ship remains found in the Canale Anfora (Beltrame and Gaddi, 2013: 299 and 301). Their exact function is not yet fully understood.

Edge joinery

The planks were laced with plant fibres passed through holes spaced between 80 and 100 mm apart (Fig. 6a). The stitching pattern is currently being studied by a Texas A&M student. The diameter of the holes was *c.* 12 mm, and the wedges, *c.* 45 mm long, tapered from 13–14 mm on the inner surface of the planks to 7–8 at the other extremity (Fig. 6d). Most holes were cut at an angle of 45–55° and are barely apparent on the outer surface of the planking (Fig. 6e). On the inner surface these holes end in triangular recesses (Fig. 6b),

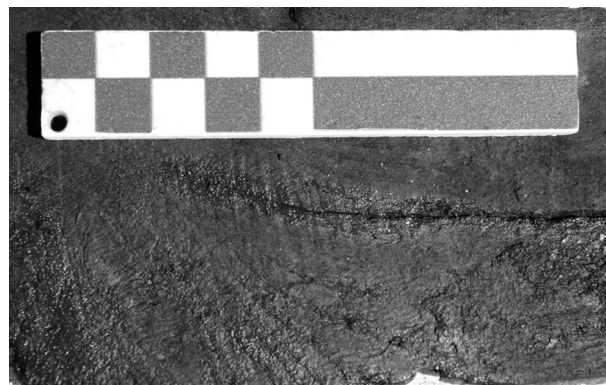

Figure 4. Saw marks on side plank SP2. (Filipe Castro)

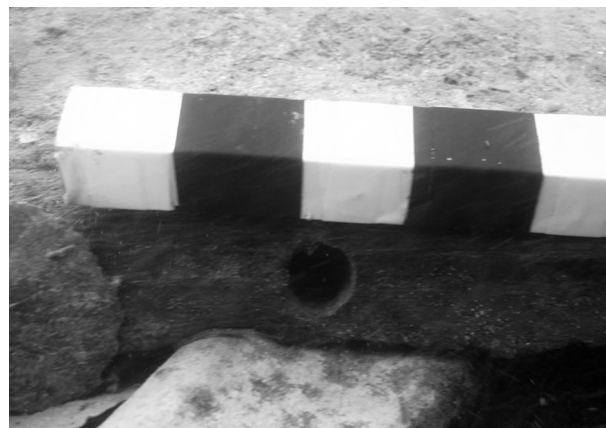

Figure 5. One of the holes for the dowels inserted in the side plank edge, presumably to reinforce its connection to the bottom planking. (Massimo Capulli)

cut to facilitate inserting the wedges. In certain places, however, imperfections or perceived weaknesses in the planking forced the shipwrights to drill the holes a few centimetres away from the plank edge, and carve a groove for the ligatures on the outer surface of the plank (Fig. 6f).

One single instance of an iron concretion was located that is large enough to be older than those corresponding to the modern iron nails used in the 1998 and 1999 excavations. Unfortunately, this concretion was found on a small fragment of bottom plank, broken off, and lying without a clear context. In any event, this was a small nail, and unlikely to have served a structural function in the boat construction. (F.C.)

Frames

The surviving frames were numbered from O1 to O14 ('O' for *ordinate*, in the original reports), with the suffix S or N denoting an accompanying futtock; 14 frames were recorded (Figs 3c, 7, 8, Tables 3 and 4). Twelve of the floor-timbers traverse the entire width of the bottom, while two, O9 and O11 have either been cut or made of two parts. The floor-timbers are generally flat, but some curve at one end to rise from the turn

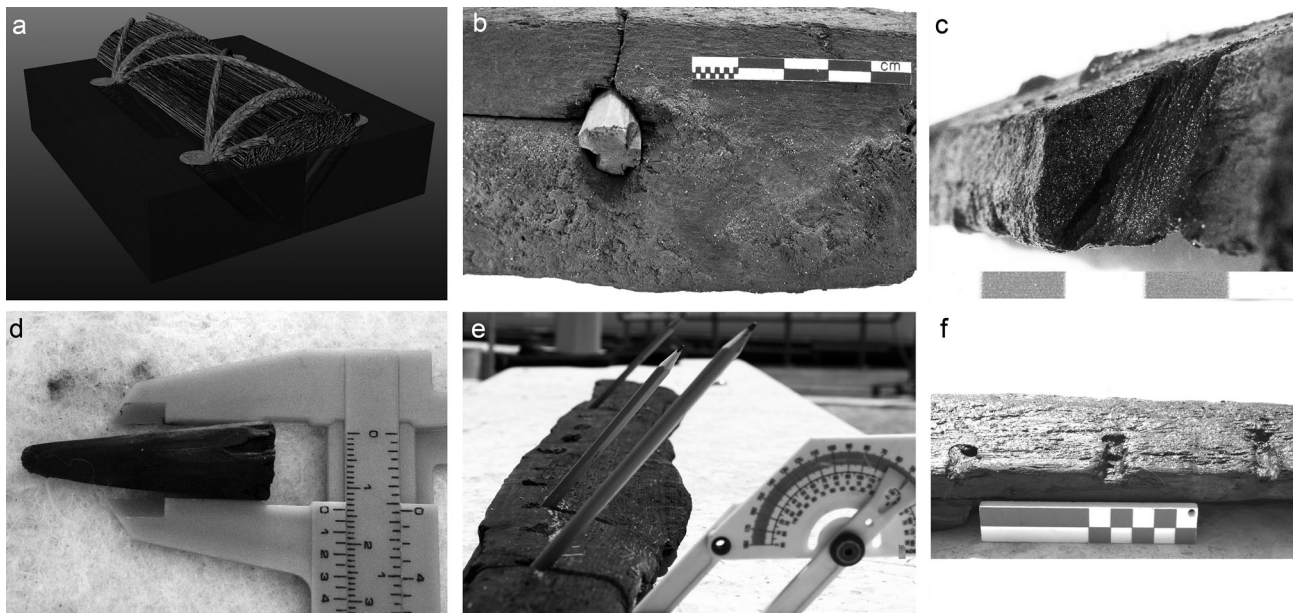

Figure 6. a) Lacing pattern (Kotaro Yamafune); b–d) wooden plug from one of the side planks; e) lacing holes along a repair on plank SP2; f) plank edge showing lacing hole and groove to lodge the lacing. (Filipe Castro)

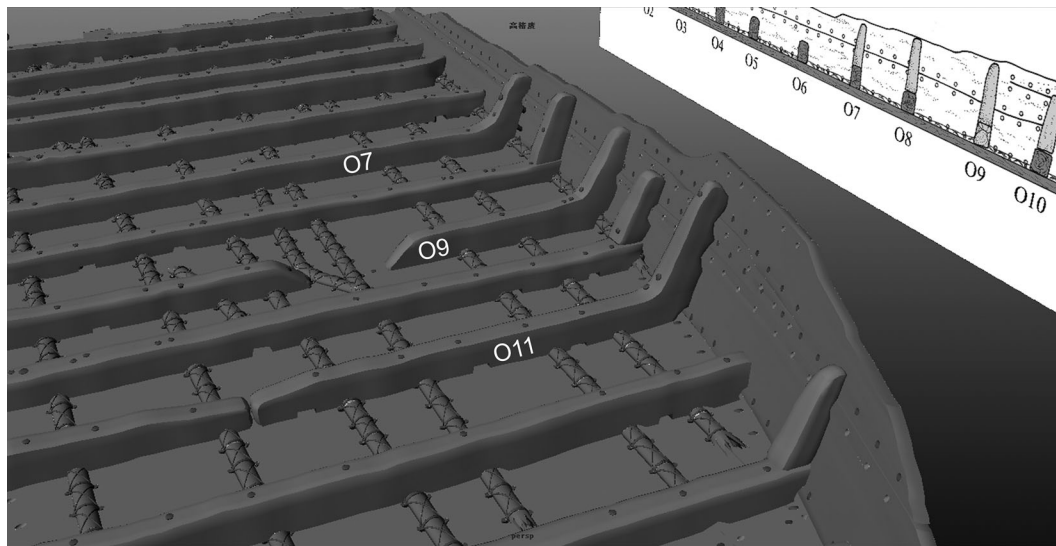

Figure 7. Surviving frames of the Stella 1 wreck: sections. (Filipe Castro and Kotaro Yamafune)

of the bilge in a short arm. Floor-timbers O7, O9 and O11 have short arms on the south side of the barge. Four futtocks were found O8S, O10S, O13S, and O13N, although none are fully preserved. None is fastened to the floor-timber, although futtock O13S had a flat scarf, which fits tightly with the correspondent floor O13. Although incomplete and inconsistent it appears that at least some short arms and futtocks are arranged in an alternating pattern.

All floor-timbers seem to have been cut from small trees. As floor-timbers O1, O2, and O3 were broken, sections were brought up and found to have respectively 22, 25 and 14 tree rings preserved from the pith to the

waney edge. The shape and size of the floor-timbers varied (Table 3) and their fore and aft surfaces seem to vary according to the original size of the timbers. Where tool marks were preserved, it seems that both fore and aft faces were sawn when the timbers were large enough (O4, O5, and O6), sawn on one face and roughly adzed on the other (O1, O2, O3, O8, O9, O10, O11, and O12), or adzed on both sides (O7) when of smaller dimensions. Floor-timbers O13 and O14 do not have preserved tool marks. All floor-timbers' upper and lower faces were adzed. Notches had been cut on their lower faces to fit over the wadding, all cut with adzes, and at least two of the limber holes preserved were

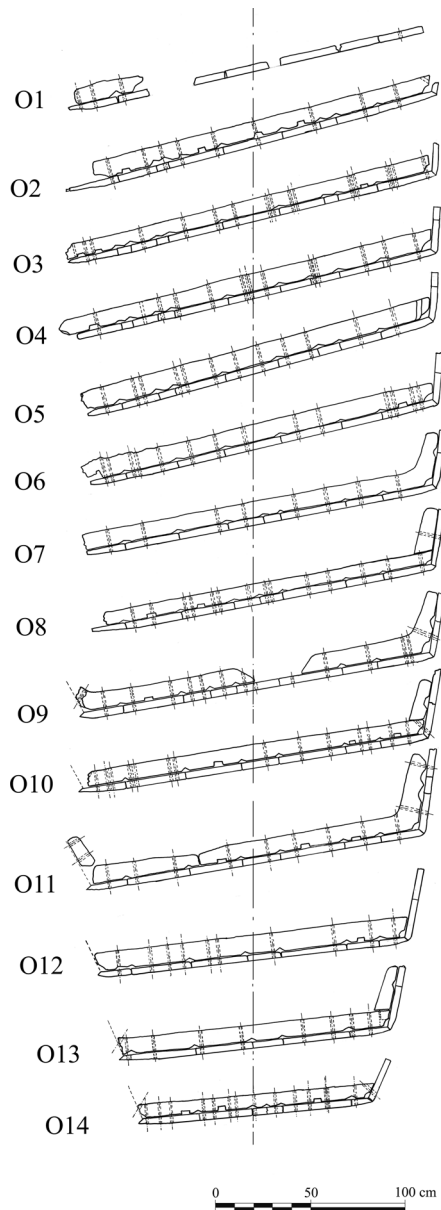

Figure 8. Floor timbers with short arms: O7, O9 and O11. (Kotaro Yamafune)

Table 3. Dimensions of the floor-timbers

Floor-timbers	Preserved length (m)	Sided (m)	Moulded (m)
O1	0.385	0.06	9
O2	1.87	0.07	9/6
O3	2.01	0.07	8
O4	2.02	0.08	10
O5	1.94	0.055/0.065	10/9
O6	1.93	0.06–0.07	9
O7	1.91	0.055–0.065	9
O8	1.80	0.05	7.5/8.5
O9	0.975 + 0.73	0.065–0.07	9
O10	1.83	0.06/0.075	8.5/9.5
O11	1.80	0.055/0.075	7/8.5
O12	168	0.095	10
O13	146	0.06	9/8
O14	127	0.09	7

cut by sawing two vertical lines 35–40 mm apart, and chiselling out the wood between them. Limber holes were observed on all floor timbers except O5, O7, and O13. They were not cut along a particular fore and aft line, and several were crossed by treenails (on O2, O4, and O8). Floor timber O2 had four limber holes, floor timbers O10 and O14 had three, and O8, O11, and O12 had two. (F.C.)

Ceiling

The ceiling was designated with the letter ‘P’ in the original report (for *pagliolato*) (Table 5). It seems to have been sawn, although their surfaces were not preserved well enough to show clear saw marks. Its thickness varied little, averaging 30 mm. The ceiling was not fastened to the frames. One of the planks (P7), however, is notched to fit over the futtocks and short arms of the floor-timbers on the side of the barge (Fig. 9). (F.C.)

Separate structure

A long wooden structure, found near the shipwreck in 1999, has been interpreted as the bottom of a revetment

Table 4. Dimensions of the futtocks (*eroded, **approximated values)

Side timbers	Shape	Preserved length (m)	Sided (m)	Moulded (m)
O7S	Floor-timber with short arm	0.22	0.04	0.08
O8S	Futtock fastened to a side plank	0.30	0.07	0.07
O9S	Floor-timber with short arm	0.24	0.07	0.085
O9N	Floor-timber with short arm	0.04*	0.06	0.07
O10S	Futtock fastened to side planking	0.22*	0.06	0.07
O11S	Floor-timber with short arm	0.32	0.06	0.12
O11N	Futtock fastened to side planking	0.20*	0.04*	0.07
O13S	Futtock scarved to floor-timber, presumably fastened to the side planking	0.23*	0.07**	0.07**

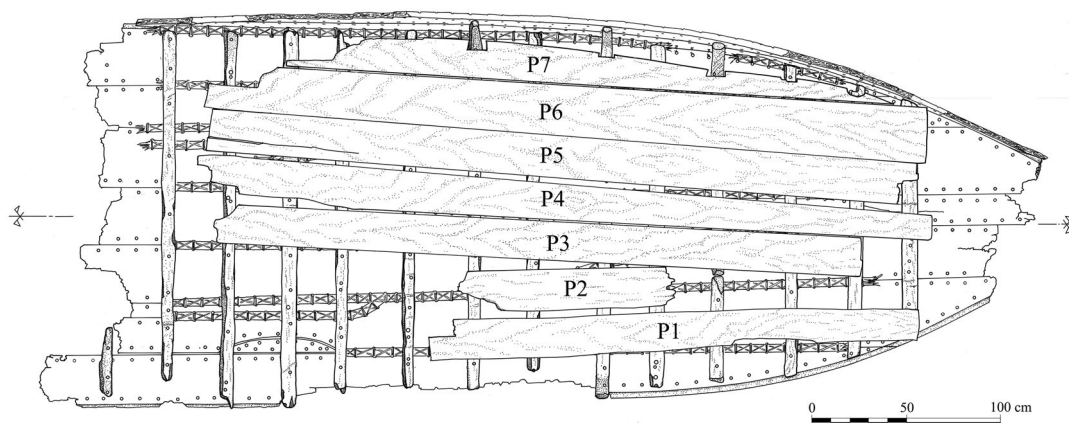

Figure 9. Ceiling planking of the Stella 1 wreck. (Filipe Castro and Kotaro Yamafune)

Table 5. Dimensions of the ceiling

Plank	Preserved length (m)	Width (m)
P1	2.64	0.18–0.22
P2	1.17	0.22–0.23
P3	3.51	0.21–0.23
P4	3.97	0.14–0.235
P5	3.82	0.225–0.235
P6	3.90	0.25–0.31
P7	3.28	0–0.20

that once protected the banks of the Stella River that has since been eroded and dragged to the centre of the river (Figs 2 and 10). The possibility remains that this structure is part of a second hull, the upper works of the Stella 1 barge, or that it is made of reused boat timbers, but further analysis is required. It was found buried in a layer of silt with abundant leaves and twigs, and standing on a layer of compact sand without apparent vegetable remains. Its preserved upper face lay slightly deeper than the bottom of the adjacent barge, which was also partially buried in the silt layer with twigs and leaves.

The structure is approximately 7 m in length, and is slightly curved at its northern extremity. It is composed of two layers of planks; the outer layer consists of two strakes edge-joined with pegged mortise-and-tenons. Evidence of edge fasteners on the inner layer, of only one thick plank, has not been found. The lower strake of the outer layer is 210 mm wide and 60 mm thick at the bottom edge but has a chamfer the length of the top edge reducing it to 40 mm. The second strake is 40 mm thick and only partially preserved; no width measurement can be determined. The mortises are spaced 90–120 mm apart and 8–10 mm wide, 60–80 mm long, and 60–80 mm deep. The tenons are *c.* 50 mm wide, 7 mm thick and 120 mm long. The pegs are 16 mm in diameter. The lower strake is formed of two planks joined in a diagonal scarf. There were no visible pegs

in the scarf, but a small iron nail was inserted near it, through which ran a vertical fracture.

The inner layer is a single eroded plank, preserved over a length of approximately 2.70 m and is 60 mm thick and 130 mm wide.

Towards its south side, four vertical timbers were preserved, treenailed to the outer layer of planking. The inner layer of planking is nailed to the vertical timbers with iron nails about 120 mm in length, with 50 mm-square heads. The position of a fifth timber, could be deduced from a nail hole on the preserved inner plank. There were no treenail marks on the central portion of the outer plank, but two treenails are clearly visible towards the north end on this plank.

A narrow pole, preserved for a length of 0.43 m and 40 mm in diameter, had been inserted between the outer and inner layers of planking, at the north end of the structure, and secured with a longitudinal timber inserted between two timbers. The longitudinal timber measured 0.36 m in length—the space between timbers—and presented a section 80 × 105 mm. The top of the pole was squared and inserted in a mortise cut on the south side of this timber.

Another similar pole was found lying under the structure, and a small timber with a tenon at one end was found buried in the sand layer beneath the silt layer that covered the structure. The upper 0.10 m of this sand layer covered more broken timbers, including fragments of planks, one of which presented a preserved section 30 mm thick and 150 mm wide. (F.C.)

Dispersion area

An area 8–10 m wide extends 80 m upstream of the wrecked barge and contains a spread of dispersed artefacts. The collection observed and recorded is composed mostly of building materials, such as *imbrices*, *tegulae* and bricks, similar to those recovered on the barge itself in 1998 and 1999. In 2013, the recovery and inventory of the artefacts started, with the

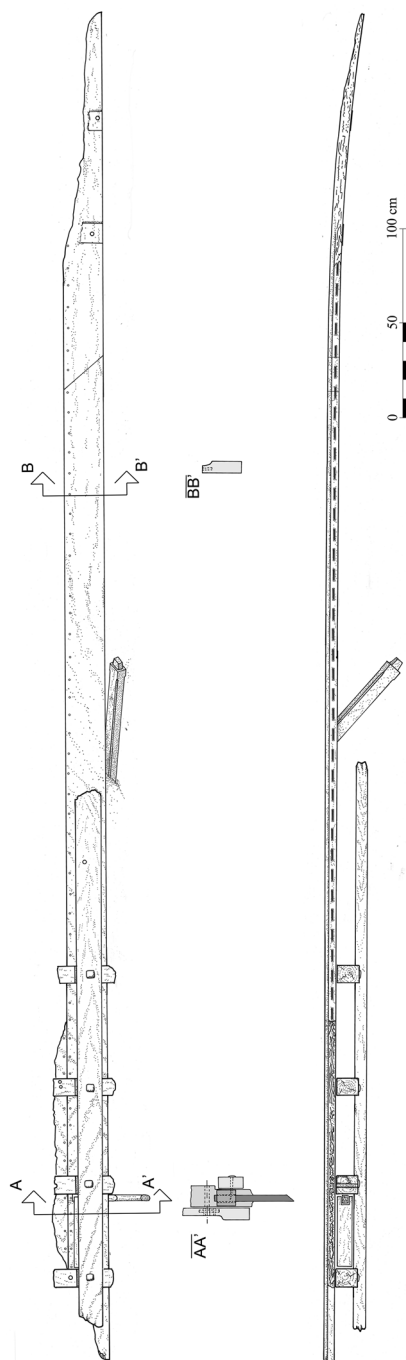

Figure 10. Plan and view of the structure found next to the Stella 1 Shipwreck. (Filipe Castro)

aim of understanding whether all the finds belonged to the Stella 1 cargo, and acquiring more data pertaining to the size of the boat.

The area was divided in 2×2 m grid squares; every square was mapped and excavated, the artefacts divided by type and weighed (Fig. 11). By the close of the 2015 season we had mapped and excavated about 25% of

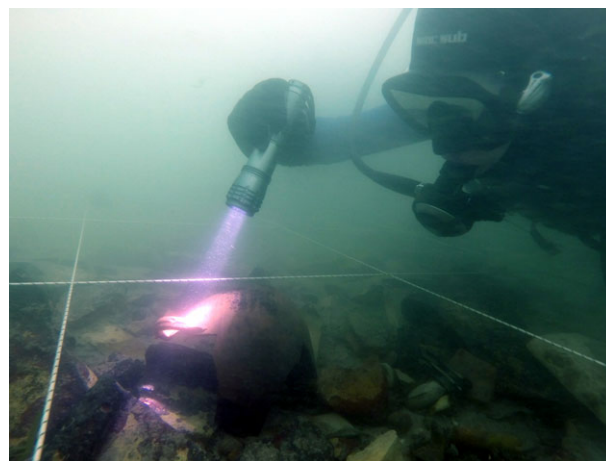

Figure 11. Aspect of the dispersion area. (Massimo Capulli)

the area: a total of 36 squares. The recovered material weighs 7622 kg. Imbrices and tegulae represent 88% of the finds by weight, but there are also about 1500 other artefacts of significant historical and scientific value including amphoras, *terra sigillata* and other fine pottery, coins and so on, which are currently being studied.

The most recent discoveries include three additional makers names found on *imbrices*: two are too incomplete to fully identify, the third is *Lucii Statii Iusti*. Six additional amphora types have also been found, that have extended the chronology of the site. (M.C.)

Dating

The barge was originally dated by the *in situ* cargo to the first quarter of the 1st century AD (Vitri *et al.*, 2003). Radiocarbon dating carried out under the Sutiles project (Willis and Capulli, 2014: 11) would move this date to the second half of the 1st century AD. However, finds from the spill area upstream, which may include intrusive materials, have extended the site chronology up to the 4th century AD. Moreover, coins recovered date between the end of the 1st century BC and the middle of the 2nd century AD. The excavation will be continued during the summer 2016 and it is hoped that future works will clarify the true nature of this site and the dimensions of the Stella 1 shipwreck. (M.C.)

Discussion

As part of an architectural tradition, the Stella 1 boat is a rare example of an upper Adriatic laced barge (Boetto and Rouse, 2011). As mentioned above, although a considerable number of these vessels has been found, few have been fully published (Table 1). Giulia Boetto and Corinne Rouse proposed a taxonomy for upper Adriatic laced watercraft, which



Figure 12. Wooden model of the Stella 1 barge wreck made by Kotaro Yamafune and Ralf Singh-Bischofberger. (Kotaro Yamafune)

separates two regional shipbuilding traditions. The first encompasses the north-western Italian region, from the Po delta to Aquileia (*romano-padane* tradition), and a second (*romano-illyrienne*) on the eastern Adriatic coast (Boetto and Rouse, 2011). The Stella 1 architectural signatures—a flat bottom, lacing over a strip of wadding, and the floor timbers treenailed to the planking—put this barge within the western Adriatic *romano-padane* tradition (Boetto, Pomey, and Tcherna, 2011: 14).

Eric Rieth and Marc Guyon (2010), and Patrice Pomey (2011), summarized the theoretical questions raised by such a find. As an artefact each boat is unique but can be classified and understood in a cultural context, within a given array of possible technological solutions. Its form, structure, proportions and dimensions—what Rieth calls the construction principle—define the Stella 1 boat as a particular type: a flat-bottomed barge (of unknown length) built according to a principle known as bottom-based. In this type of vessel the bottom is laid down first by juxtaposing a certain number of longitudinal planks on the floor or, more specifically, over a number of transversal beams that allow the shipwright to fasten and lace the planks together, or later to add a series of close-spaced floor-timbers, without hitting the floor with his tools, fastenings, or other construction features.

The construction sequence described above—bottom, floor-timbers, sides, and futtocks—defines this boat within a narrower collection of technological solutions: the Stella 1 boat is a bottom-based barge whose planks have been laced together with local vegetable fibres over a strip of wadding whose functions are to prevent the passage of water through the bottom

seams and to avoid sharp angles that might damage the lacing. This construction solution is typical of the upper Adriatic region in the last centuries BC and the earlier half of the 1st millennium AD, both according to the testimony of ancient and medieval authors (Beltrame, 1996, 92–3) and a number of archaeological finds (Capulli and Pellegrini, 2010; Boetto and Rouse, 2011; Beltrame and Gaddi, 2013). (F.C. & M.C.)

Conclusion

Many questions regarding the Stella 1 barge remain unanswered at this point. It was likely lost during a flood, breaking and spilling its cargo as it drifted downstream. The fragment presented here ended up half buried at a very shallow depth on the left bank of the Anaxum River. It is not clear why the portion of the cargo left behind was not salvaged as soon as the water-level subsided. At this point we do not know the length of the vessel, and no other fragment of this boat has been found. We have recorded the Stella 1 timbers and made two models, one in wood, at a 1/10 scale (Fig. 12), and another virtual, at full size. Our next steps include the elaboration of a series of hypothetical reconstructions for several lengths and cargo configurations in order to assess the more plausible ranges of sizes of the original Stella 1 barge.

In 2013–2015 the Anaxum Project included further research on the artefact dispersion area to the north of the shipwreck, including the mapping, inventory, and recovery of and the artefacts upstream of the shipwreck. The results promise to shed light on the nature of the cargo, the site formation process, and the size of the boat. (F.C. & M.C.)

Acknowledgements

The authors would like to thank the Soprintendenza Archeologia del Friuli-Venezia Giulia, ProMare, CMAC, Peter and Nancy Amaral, Mario and Giovanna De Candido (Marina Stella), and the joint team from the University of Udine (Lucrezia Maria Federico, Massimo Iob, and Daniel Iacumin), Promare (Ayse Atauz, Peter Holt, Dante Bartoli, and Lindsey Thomas), and Texas A&M University (Kelby Rose and Kotaro Yamafune).

References

- Balista, C. and Ruta Serafini, A., 1993, Saggio stratigrafico press il muro romano di largo Europa a Padova. Nota preliminare. *Quaderni di Archeologia del Veneto IX*, 95–111.
- Bartoli, D., Capulli, M. and Holt, P., 2012, Creating a GIS for the Underwater Research Project ANAXUM: the Stella 1 Shipwreck, in L. Fozzati and V. Roberto (eds), *The New Technologies for Aquileia, Proceedings of the 2nd Workshop on The New Technologies for Aquileia (Aquileia Italy, June 25, 2012)*, E1-E9. <http://ceur-ws.org/Vol-948/paper5.pdf> (Accessed 15/11/2015)
- Beltrame, C., 1996, La sutilis navis del Lido di Venezia. Nuova testimonianza dell'antica tecnica cantieristica 'a cucitura' nell'alto Adriatico, in F. Ciciliot (ed.), *Navalia. Archeologia e storia*, 31–53. Savona.
- Beltrame, C., 2002, Le *sutiles naves* romane lungo il litorale alto Adriatico. Nuove testimonianze e considerazioni tecnologiche. *Archeologia subacquea, studi, ricerche e documenti 3*, 353–79.
- Beltrame and Gaddi, 2013, Fragments of Boats from the Canale Anfora of Aquileia, Italy, and Comparison of Sewn-Plank Ships in the Roman Era. *IJNA 42.2*, 296–304.
- Bertacchi, L., 1990, Il sistema portuale della metropoli aquileiese. *Aquileia e l'arco adriatico Antichità Alto Adriatiche XXXVI*, 227–53.
- Berti, F., 1990, *Fortuna maris: la nave romana di Comacchio*. Bologna.
- Boetto, G. and Rousse, C., 2011, Le chalands de Lipe (Ljubljana, Slovénie) et la tradition de construction 'sur sole' de l'Europe sud-orientale: quelles influences méditerranéennes? in G. Boetto, P. Pomey and A. Tchernia (eds), *Batellerie gallo-romaine, pratiques régionales et influences maritimes méditerranéennes*, 179–91. Paris.
- Boetto, G. and Rousse, C., 2012, Traditions régionales d'architecture navale en Adriatique à l'époque romaine. *Histria Antiqua 21*, 427–41.
- Boetto, G., Pomey, P. and Tchernia, A. (eds), 2011. *Batellerie Gallo-Romaine. Pratiques Régionales Maritimes et Influences Méditerranéennes*. Paris: Errance.
- Bonino, M., 1968, Tecniche costruttive navali insolite nei reperti di Cervia, Pomposa e Pontelagoscuro, in A. Longo (ed.), *Atti del Convegno Internazionale di Studi sulle Antichità di Classe*, Ravenna. 1967, 209–17. Ravenna.
- Bonino, M., 1978, *Archeologia e tradizione navale tra la Romagna e il Po*, Ravenna.
- Brusić, Z. and Domjan M., 1985. Liburnian Boats—Their Construction and Form, in S. McGrail, and E. Kentley (eds), *Sewn Plank Boats: Archaeological and Ethnographic Papers Based on Those Presented to a Conference at Greenwich in November 1984*, 67–86. BAR International Series 276.
- Capulli, M., 2010, Il mare di Aquileia. I traffici commerciali e il controllo militare dell'alto Adriatico, in L. Fozzati (ed.), *Aquileia Patrimonio dell'Umanità*, 88–107. Udine.
- Capulli, M., 2013, Ships of Aquileia. Underwater Archaeological Research for the study of marine and inside routes in the Upper Adriatic Sea. *Skyllis, XIII*, 18–23.
- Capulli, M., 2014a, Waterlands. The eco-historical landscape of the Stella River. *Skyllis XIV*, 20–25.
- Capulli, M., 2014b, Progetto ANAXUM. Studio di un paesaggio archeologico fluviale. *l'Archeologo Subacqueo XX 2(59)*, 13–16.
- Capulli, M. and Castro, F., 2014, Navi cucite di epoca romana: il caso del relitto Stella 1, in A. Asta, G. Caniato, D. Gnola and S. Medas (eds), *Atti del II Convegno Nazionale, Cesenatico (NAVIS 5)*, 35–41. Padova.
- Capulli, M., and Pellegrini, A., 2010, Tavole cucite dall'isola di San Francesco del Deserto (Venezia), in *Atti del I Convegno Nazionale, Cesenatico (NAVIS 4)*, 263 6. Bari.
- Capulli, M., Pipan, M. and Mocnik, A., 2013, Progetto ANAXUM. Studio di un paesaggio archeologico fluviale e sviluppo di tecniche geofisiche integrate, in L. Botarelli and D. La Monica (eds), *Conoscenza e tutela del patrimonio sommerso (Atti del Convegno Scuola Normale Superiore di Pisa)*, 185–98. Roma.
- Cipriano, S., 2011, La suddivisione agraria del territorio altinate: primi dati archeologici, in G. Cresci Marrone and M. Tirelli (eds), *Altino dal cielo: la città telerivelata. Lineamenti di Forma Urbis. Atti del convegno, Venezia 2009*, 81–94. Roma.
- Dorigo, W., 1983, *Venezia Origini. Fondamenti, ipotesi, metodi*, vol. 1, 247. Milano.
- Fozzati, L., Capulli, M. and Castro, F., 2012, The Stella 1 Shipwreck, Udine, Italy, *CMAC News & Reports 3*, 2.
- Gomezel, C., 1996, *I laterizi bollati romani del Friuli-Venezia Giulia: analisi, problemi e prospettive*. Portogruaro.
- Pomey, P., 2011. Introduction. Nouvelles perspectives de recherche sur la batellerie gallo-romaine, in G. Boetto, P. Pomey and A. Tchernia (eds), *Batellerie gallo-romaine, pratiques régionales et influences maritimes méditerranéennes*, 9–15. Paris.
- Radić, Rossi I. and Boetto, G., 2010, Arheologija broda i plovidbe—Sivani brod u uvali Caski na Pagu, Istrazivacka kampanja 2009. *Histria Antiqua 19*, 299–307
- Rieth, E., 1998, *Des bateaux et des fleuves. Archéologie de la batellerie du Néolithique aux Temps modernes en France*. Paris.
- Rieth, E. and Guyon, M., 2010, Les épaves gallo-romaines, in E. Rieth (ed.), *Les épaves de Saint-Georges Lyon, Ier-XVIIIème siècle. Archeonautica 16*, 35–47.
- Sanesi, L., Bonomi, S. and Toniolo A., 1986, L'insediamento romano di Corte Cavanella di Loreo. *Quaderni di Archeologia del Veneto II*, 25–30.

- Tiboni, F., 2009, Chioggia. Località di Motta di Cavanella d'Adige. Le operazioni di scavo e primo studio di un relitto del II-I secolo a.C. *Quaderni di Archeologia del Veneto* **XXV**, 82–4.
- Trovò, R., 1996, Canalizzazioni lignee e ruota idraulica di età romana ad Oderzo (Treviso). *Quaderni di Archeologia del Veneto*, **XII**, 119–34.
- Uhač, K., 2009, Povodna arheoloska istraživanja u uvail Zambratija (Underwater archaeological investigation in the bay of Zambratija). *Histria Antiqua* **17**, 263–68.
- Uhač, I. and Uhač, K., 2012. Prapovijesni brod iz uvale Zambratija—Prva kampanja istraživanja. *Histria Antiqua* **21**, 533–8.
- Vitri, S., Bressan, F. and Maggi, P., 1999. Scavo subacqueo e protezione del relitto Stella 1. Interventi 1998–1999. *Aquileia Nostra* **LXX**, 435–40.
- Vitri, S., Bressan, F., Maggi, P., Del'Amico, P., Martinelli, N., Pignatelli, O. and Rottoli, M., 2003, Il relitto romano del fiume Stella (UD), in L. Fiamma (ed.), *L'Archeologia dell'Adriatico della Preistoria al Medioevo. Atti del Convegno Internazionale* (Ravenna 1–8–9 giugno 2001), 324–38. Roma.
- Willis, S. and Capulli, M., 2014, Putting the pieces together. The laced timbers of the Venice Lido III assemblage. *INA Quarterly* **41.2**, 10–15.