

A Parametric Approach for Evaluating the Stability of Agricultural Tractors Using Implements during Side-Slope Activities

Marco Bietresato

Faculty of Science and Technology - FAST
Free University of Bozen-Bolzano
Piazza Università, I-39100 Bolzano, Italy

Giovanni Carabin

Faculty of Science and Technology - FAST
Free University of Bozen-Bolzano
Piazza Università, I-39100 Bolzano, Italy

Renato Vidoni

Faculty of Science and Technology - FAST
Free University of Bozen-Bolzano
Piazza Università, I-39100 Bolzano, Italy

Fabrizio Mazzetto

Faculty of Science and Technology - FAST
Free University of Bozen-Bolzano
Piazza Università, I-39100 Bolzano, Italy

Alessandro Gasparetto

Department of Electric, Managerial and Mechanical Engineering (DIEGM)
University of Udine, Via delle Scienze 206, 33100 Udine, Italy

Abstract

A methodological approach for evaluating a priori the stability of agricultural vehicles equipped with different mounted implements and operating on sloping hillsides is shown here. It uses a Matlab simulator in its first phase and, subsequently, the Response Surface Modelling (RSM) to evaluate the coefficients of a set of regression equations able to account for the Type-I and Type-II stability of the whole vehicle (tractor + implement with known dimensions and mass).

The regression equations can give reliable punctual numeric estimations of the minimum value of the Roll Stability Index (RSI) and can verify the existence of a Type-I equilibrium without the need of using the simulator or knowing any detail about the model implemented in it. The same equations can also be used to generate many intuitive graphs ("*equilibrium maps*") useful to verify quickly the possible overturning of the vehicle.

A case-study concerning a 4-wheel drive articulated tractor is then presented to show the potential of the approach and how using its tools. The tractor has been studied in three scenarios, differing on where the implement has to be connected to the tractor (1: frontally; 2: frontally-laterally; 3: in the back). After performing a series of simulations, a set of polynomial models (with 6 independent variables) has been created and verified. Then, these models were used, together with the related equilibrium maps, to predict the stability of 8 implements for scenario 1, 7 implements for scenario 2, and 3 implements for scenario 3, evidencing in particular the danger of using a lateral shredder with a mass greater than 245 kg.

The proposed approach and its main outcomes (i.e., the regression equations and the equilibrium maps) can give an effective contribution to the preventive safety of the tractor driver, so it could be useful to integrate it in the homologation procedures for every agricultural vehicle and to include the resulting documentation within the tractor logbook.

Keywords: farm tractor, side-slope agricultural activities, parametric evaluation of the stability, Response Surface Modelling, equilibrium maps

Introduction

The safety and health of agricultural workers are always very actual topics among manufacturers, engineers and scientists dealing with farm machines. All the issues related to the safety and health are generally multifactorial and include a lot of machine-, environmental- and man-related aspects having an immediate (*accidents*) and/or life-lasting (*occupational diseases*) influence on the workers' welfare or life [1,2]. For these reasons, notwithstanding the complexity of these topics and the potential difficulty of finding viable technical solutions, a continuous work of improvement on agricultural machines to minimize the risk factors can have important repercussions also for the society [1-4].

In particular, vehicles working in agricultural side-slope activities can easily reach critical conditions from the point of view of their stability [5-10]. Therefore, the

mechanization of side-slope activities [11] and, in general, the dynamic behaviour of off-road vehicles has been studying since the eighties and it is still an open field of investigation.

The many cases of rollovers, happening frequently still nowadays, are due to a combination of many factors, spanning from the slope of the hill-side on which the tractor is operating, to the specific manoeuvre in execution (especially: turnings), to the presence of an implement connected to the tractor, altering considerably the balance of the vehicle. Due to the intrinsic difficulty to keep all these variables under control when agricultural machines, in particular tractors, are operating on steep hillsides, one of the most interesting challenge is *predicting the possible rollover of a vehicle*, thus preventing the damages and the risks caused by an eventual overturning.

The situation of incipient rollover of a vehicle can be described through analytical equations addressed in two different ways: (i) energetic or (ii) Newtonian.

For example, the use of the energetic approach in [12] allowed to analyse the different initial rollover conditions of tractors and to evaluate the energy available at rollover start. However, the most recent works analysing the stability of agricultural machines [13,5,9,14] use an analytical-Newtonian approach combined with a kineto-static approach based on rigid bodies: the rollover initiation angle of conventional farm tractors fitted with front-axle pivot is studied in [13] while the articulated tractors are treated in [14,5]. The approach followed in the kinematic description of these two types of tractors is basically the same: a first (anterior) body groups the front axle and wheels and a second (posterior) body the remaining part of the machine and the rear wheels. Conventional tractors have been studied also in [15] through a dynamic model capable of investigating the effects of forward speed, ground slope and wheel-ground friction coefficient on the lateral stability at the presence of position disturbances. Other works, based on the same Newtonian approach, consider also a three-dimensional tire-terrain interaction model [16] or the effects of the rear track width and of an additional weight placed on the wheels, on the stability of a tractor when driving on side slopes [7].

If an agricultural implement or a trailer is connected to a tractor, the static and dynamic behaviour of the whole vehicle (tractor + implement/trailer) is substantially different from the behaviour of the same tractor alone: a tractor that is normally stable on a sloping ground could easily and unexpectedly reach critical conditions if carrying or pulling an implement. Therefore, many authors focused their attention on these cases, probably more complex than the situations referred to a single tractor but, surely, more common in everyday agricultural works. For example, a linear dynamics model of tractor + trailer with six degrees of freedom (DoFs) is presented in [17]: it is used to evidence the critical situations occurring when avoiding an obstacle, i.e. the rearward amplification phenomenon. In [18] a sensitivity analysis on a model of a tractor with a single-axle grain cart allowed to identify the effect of uncertainty/variation of some parameters on the lateral dynamics of the system. In [19] a very critical case, represented by a tractor equipped by a front-end loader or a forklift system, is studied when braking and moving the load on the forks while descending on a slope.

The present work uses an approach similar to [13,5,9,14] for the calculation of the stability of a vehicle and deals with *articulated farm tractors*, i.e. wheeled agricultural tractors having a central joint used for steering [20-22]. Due to the particular architecture of these tractors, beside a higher agility and a lower turning radius than conventional tractors with the same dimensions, they have a supporting polygon that varies with the steering angle [9]: their behaviour is very different from conventional tractors and, maybe, not completely predictable in all situations by inexperienced drivers. Then, the rollover angle of an articulated tractor is calculated in a quasi-static condition and in several slope and angular conditions. The attitude of the tractor to be stable is quantified by a single number, called *Roll Stability Index (RSI)*, in a way similar to [23] and [24]. The more this index is close to zero, the more the vehicle is next to reach a possible overturn condition; so, this index could be very useful as input signal for activating many real-time active safety devices, acting for example on: the braking system, the limited-slip differentials [25], the variable-geometry roll-over structures [26], the self-levelling cab system [27]. As proposed in this study, the same index can be calculated also for a tractor having a mounted implement and then it can be used: (1) to inquiry several configurations of “tractor + implement” and compile a series of tables, (2) to calculate some regression equations giving the minimum RSI starting from the values reported in these tables and, then, (3) to generate also a set of “stability maps”, i.e. a graphical tool having many uses.

The *regressions equations* are a very interesting tool because they can be used to obtain quickly an estimation of the minimum value of the RSI instead of the simulator also by people not knowing any detail of it and without the need to interpret the simulators results. The *stability maps* can be also useful to end-users: for example, they can be consulted by a farm manager to value the opportunity to purchase a new implement that does not expose his workers' life to risks, or by a driver to known a priori which implement (among the many at his disposal) can be used in the specific parcel he is going to work.

In all the illustrated cases, the proposed tools can give a contribution to the safety of the tractor driver and therefore they should be given (e.g., also on an electronic support like a DVD-ROM) together with the tractor logbook, to follow the vehicle in all his future property transfers.

1.2.Aims of this work

The main purpose of this work is to propose a methodological approach for evaluating a priori the stability of an agricultural vehicle equipped with different mounted implements, with known dimensions and masses, and operating on hillsides. Secondly, it aims at explaining how using the main outcomes of the proposed approach (i.e., a set of regression equations that can be used to generate many intuitive graphs, named “equilibrium maps”) for accounting for the shift of the centre of gravity of the whole vehicle and, therefore, for assessing the opportunity to couple the tractor with any implement.

Materials and Methods

1.1 The studied articulated tractor

The agricultural tractor studied in this work is a very compact 4-wheel drive articulated tractor, thought to operate within vineyards and orchards placed on steep hillsides (Figure 1, Figure 2, Table 1). In fact, it has a narrow track and a low centre of gravity (CoG), its engine is housed in the front part and the reversible driving seat is placed immediately above the motor. In particular, these latter solutions give the driver a very high visibility from his seat and grant the tractor the maximum flexibility of use. The hydrostatic transmission adopted to drive the wheels simplifies the power connections between its front and rear halves. The rear part can be used as a loading platform or to house a series of specifically-designed implements (e.g., a sprayer). Therefore, the tractor is configured as an implement-carrier.



Figure 1 – (left) Scheme of the studied articulated tractor; (right) overview of one of the first prototypes equipped with a front-coupled mower and a rear dumper

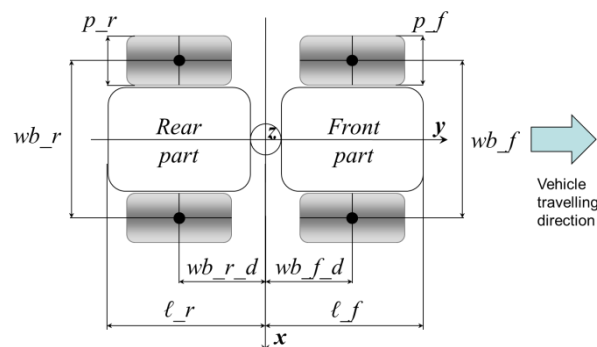

Figure 2 – Main dimensions of an articulated wheeled tractor and used frame of reference (z axis is perpendicular to the supporting plane of the tractor and is pointing towards the observer, in accordance with the right-hand rule).

The steering is made by means of the central articulation (or “joint”) of the chassis, linking together the two parts which compose the vehicle, each one with an axle

with two wheels. The central joint has two DoFs (yaw and roll): one hydraulically-operated through a joystick (i.e., the yaw, used for making the tractor steer) and the other passive (i.e., the roll, to allow the vehicle to comply with the terrain, even very harsh). In fact, this vehicle changes its travelling direction by modifying the angle between the two parts composing the chassis (according to the driver requests), thus realizing a certain angulation of the axles (and, consequently, of the wheels keyed on those axles) and individuating a centre of rotation for the vehicle on the horizontal plane [9].

The described design features give the vehicle a very high agility but this steering modality, affecting the baseline dimensions and shape, the presence of a passive DoF of the joint and the equipment of the tractor with an implement in its front or rear part, modifying the balance, could be potentially critical for the stability of the vehicle.

Table 1 – main geometrical and mechanical parameters referred to the articulated tractor (*f*: front part; *r*: rear part; for other abbreviations refer to Figure 2).

Quantity	Value
<i>CoG_f position</i> (*)	[0.011, 0.621, 0.270] m
<i>CoG_r position</i> (*)	[0.000, -0.618, 0.159] m; [0.000, -0.500, 0.000]** m
<i>ℓ_f; ℓ_r</i>	1.226 m; 0.923 m
<i>wb_f; wb_r</i>	0.710 m; 0.685 m
<i>wb_f_d; wb_r_d</i>	0.669 m; 0.669 m
<i>p_f; p_r</i>	0.200 m; 0.200 m
<i>Joint height</i>	0.280 m
<i>Mass(es)</i>	650 (f) + 344*** (r) kg
<i>Maximum steering angle</i>	110° between the two tractor halves

(*) coordinates referred to a local coordinate system, placed as drawn in Figure 2; (**) without any ballast on the rear end; (***) when no implement is placed on the rear end (149 kg), a ballast (195 kg) is used.

1.2 The proposed approach

The prediction of the minimum value of the RSI or the forecasting of the equilibrium conditions of a generic tractor equipped with a generic implement (whose mass and CoG should be known) can be done by following the approach presented here, articulated in the following phases:

1. Generation of stability regression equations and equilibrium maps
 - a. Experimental acquisition of the position of the vehicle's CoG (or of the two centres of gravity, if the vehicle has an articulated frame, as the farm tractor studied in the presented case);
 - b. Numerical inquiry of the stability of that vehicle (in particular calculation of the minimum RSI value) by means of a Matlab simulator capable of recalculating, in several angular configurations, the positions of the vehicle's centre of mass with additional masses in many positions (front, rear), with the aim of including all possible implements that can be mounted on that tractor;
 - c. Calculation, through the Response Surface Modelling (RSM) technique, of

the regression equations of the RSI and of the Type-I stability; generation of a series of equilibrium maps evidencing with clear colours (green, yellow, red) when a possible rollover of the “tractor + implement” can happen;

2. Use of the regression equations and equilibrium maps for preliminary checking the safety conditions of the vehicle mounting a specific implement (having a known mass and position of the CoG - centre of gravity).

1.3 The stability simulator

The different stability conditions for the presented articulated tractor working on sloping terrains were evaluated by means of a Matlab[®] simulator, designed and developed for this purpose. The simulator implements the kinematics of the vehicle (including the behaviour of its central joint), allows the user to insert the position of the implement’s CoG and calculates the position of the CoG of the whole vehicle with respect to the stability baselines. The steering has been modelled following the classical steering kinematics [28], thus neglecting the friction contributes in the advancement direction (rolling and aerodynamic frictions). Hence, the positions of the wheels can be computed in different steering conditions in the following chosen scenario: a perfectly smooth inclined plane on which the vehicle travels along a circumference with a certain radius. The stability critical angle for the configuration “tractor + implement” is searched with respect to the slope and the angular position of the vehicle on the circumference, supposing that the vehicle never slips along the plane in any position it is (i.e. an infinite friction in the direction transversal to the advancement is supposed to be present) and its wheels stay always in contact with the plane.

As the tractor will move at reasonably low speeds during its normal operations, the dynamic stability can be realistically treated with a quasi-static approach, i.e. the inertial terms can be neglected, leaving the resulting weight of the whole vehicle as the unique force to be taken into account.

In particular, in order to assess the limit slope, if d is the state variable for evaluating the stability and d_l its limit value, a *Roll Stability Index (RSI)* has been defined and implemented [24]:

$$RSI = \left(1 - \frac{d}{d_l}\right) \cdot 100 \quad \text{with} \quad \begin{cases} RSI \in]0;100[\Leftrightarrow d \in [0; d_l[: \text{stable configuration} \\ RSI = 0 \Leftrightarrow d = d_l : \text{incipient overturning} \\ RSI < 0 \Leftrightarrow d > d_l : \text{unstable configuration} \end{cases} \quad (1)$$

The index is calculated by computing, on the travelling plane, the distance d of the projection CoG* of the CoG from the tractor line of symmetry along the maximum slope direction and the critical stability condition d_l , i.e. the distance corresponding to the scenario in which the CoG projection is on the baseline border (Type II instability; Figure 3). In this case, the instability of each part (*Type I instability*) is also evaluated by checking if the projection of the front and rear centres of mass fall inside or outside the proper stability triangle [13,14,9].

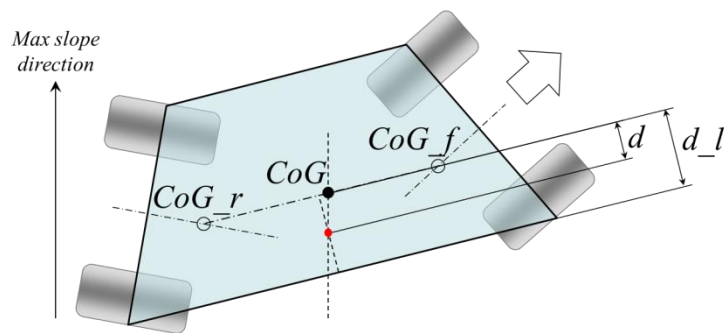

Figure 3 – Top view of an articulated tractor in a turning manoeuvre with evidenced: the positions of the centres of gravity on a perfectly horizontal ground (hollow/solid black points), the new position of the CoG projection along a line parallel to the max slope direction (solid red point, indicated as CoG*), the distances used for the calculation of the RSI and the support polygon of the vehicle (light blue).

1.4 The Response Surface Modelling

The RSM is a very effective numeric tool that allows calculating, from a set of input data, an explicit polynomial regression-function that is the best approximation, in a limited validity domain, of the real function governing the phenomenon under study [29–31]. The input data can come equally from an experimental design or a simulation design performed through a tuned model, as in this case (the RSM has been applied to the RSI values given as an output by the simulator). For each response variable (i.e., dependant variable), the same software can also give suggestions about a possible preliminary transformation (e.g., “power law”, “square root”) to be applied to the collected data to have subsequently a better fitting of data by the polynomial function. Differently from artificial neural networks [32], RSM gives as a result an explicit polynomial function (maximum degree: 3) that is therefore the first part of the Taylor series of a real function (unknown) and can be used to study or optimize a system by making some quantitative predictions about the involved quantities. At the same way, the same function can be also represented graphically in some charts to enhance the immediacy of understanding and avoiding the reader any calculation (as in the present case). If the response variable is the minimum RSI or the Type-I stability, we can speak of “*equilibrium maps for the tractor*” when referring to these charts. If y_k and $x_{i,k}$ are, respectively, the k -th predicted value of a generic response y , i.e. the independent variable (e.g., the minimum RSI) and the corresponding value of the x_i ($i=1$ to m , with m the number of inquired variables; e.g., $x_1 \equiv a$; $x_2 \equiv L$) generic numerical factor, i.e. independent variable, non-coded, a_0 is the interception coefficient, a_i , a_{ii} , a_{iii} , a_{ij} and a_{ijh} ($i \neq j \neq k$) are the coefficients of the linear, quadratic, cubic, 2nd-order and 3rd-order interaction terms, the generic regression model used in RSM is:

$$y_k(x_i; i = 1 \text{ to } m) = a_0 + \sum_{i=1}^m a_i x_{i,k} + \sum_{1 \leq i < j \leq m} a_{ij} x_{i,k} x_{j,k} + \sum_{1 \leq i < j < h \leq m} a_{ijh} x_{i,k} x_{j,k} x_{h,k} \quad (2)$$

The validity domain of the polynomial function f is given by the lower and upper values of each independent variable x_i ($i=1$ to m) and therefore is the following hyperspace:

$$Dom(f) = \prod_{i=1}^m (x_{i,\min} ; x_{i,\max}) \subseteq \mathfrak{R}^m \quad (3)$$

The ANOVA, which is part of this methodology, lets the analyst identify the most significant factors and polynomial terms, thus operating a partial simplification of the model on the basis of the p-values.

1.5 Inquired scenarios and simulation design

With the aim of generating the regression models/equilibrium maps for the RSI/Type-I stability of the tractor equipped with a generic implement (mass: M ; CoG coordinates: x_G, y_G, z_G), the stability of the whole vehicle (tractor + implement) has been evaluated in correspondence of different operating scenarios (Table 2).

Table 2 – Different scenarios inquired in this study

Scenario		Examples of implement
Ref.	Description	
1	Tractor with an implement mounted frontally and operating centrally with respect to the tractor’s longitudinal axis; the connection of the implement to the tractor is made through a properly-designed front lifter equipping the tractor	front shredder/fodder cutter; front vine-shoot shredder
2a	Tractor with an implement mounted frontally and operating laterally/not centrally with respect to the tractor’s longitudinal axis; the implement is at the external side of the turn; the connection of the implement to the tractor is made through a properly-designed front lifter equipping the tractor	lateral shredder/fodder cutter; unilateral/bilateral shoot remover; single/double sickle bar
2b	Tractor with an implement mounted frontally and operating laterally/not centrally with respect to the tractor’s longitudinal axis; the implement is at the internal side of the turn; the connection of the implement to the tractor is made through a properly-designed front lifter equipping the tractor	
3	Tractor with an implement positioned directly on the tractor’s rear end (i.e., on the plane above the rear axle)	sprayer equipment, dumper

Each of these scenarios has been inquired with different combinations of the 6 parameters influencing the tractor’s stability according to a factorial design (Table 3), i.e.: two slopes of the supporting plane, three implement total mass (frame and payload, if forecasted), many positions of the implement centre of mass (9 or 27,

depending on the scenario; see Table 3) given as Cartesian coordinates in the tractor's reference frame). The ranges of values for the parameters were chosen to include all the possible implements which can be coupled with the tractor; moreover, it is important to have at least three levels for all the parameters but the slope in order to have the chance to discover eventual nonlinear correlations of the RSI with respect to that parameter.

Table 3 – Values of the parameters inquired in each scenario

Parameter	Unit	Values		
		Scenario 1	Scenario 2a/b	Scenario 3
Ground slope (α)	°	30, 35, 40, 45, 50, 55, 60		
Trajectory radius (R)	m	2, INF*		
Implement mass (M)	kg	100, 250, 350	10, 150, 290	200, 400, 800
Distance between the implement centre of mass and the front part of the tractor (scenarios: 1, 2) or distance of the implement's CoG from the rear axle (scenario 3) (L)	m	0.4, 0.6, 0.8	0.0, 0.5, 1.2	0.0, 0.2, 0.4
Height of the implement centre of mass from the supporting plane (H)	m	0.2, 0.4, 0.6	0.2, 1.0, 1.4	0.2, 0.4, 0.6
Distance between the implement centre of mass and the tractor longitudinal axis (B)	m	0.0	-1.3, -1.0, -0.5 (0.5, 1.0, 1.3)	0.0
Number of parameters combinations	-	$7 \times 2 \times 3 \times 3 \times 3 \times 1$ (378)	$7 \times 2 \times 3 \times 3 \times 3 \times 3$ (1134)	$7 \times 2 \times 3 \times 3 \times 3 \times 1$ (378)

* INF: straight trajectory.

One of the outputs of each combination of parameters is the minimum value of the RSI. Notice that, at this point, it is not important if the RSI associated with a set of parameters has a value lower than zero (and therefore the rollover would take place): all the RSI values, whichever the sign/value they have, will be used for the individuation of the functions interpolating the RSI values within the parameters ranges.

Results and discussion

1.6 Regression equations

Thanks to the RSM, it was possible to calculate the coefficients of the regression equations for approximating the RSI_{\min} and for checking the Type-I stability/instability in all the considered scenarios (Table 2) with only the statistically-significant terms (a backward exclusion criterion with $p=0.05$ was applied). These equations can consider the numeric values of all the listed factors but the radius: in fact, the curvature radius (2 m or infinite) of the trajectory was treated as a categorical factor (Table 4). Note that Type-I stability can be expressed only as 0 (unstable vehicle) or 1 (stable vehicle) by the simulator but RSM uses only polynomial functions. Therefore, the function found through the

RSM, although it is the best fitting the data, will necessary be an approximation in an hyperspace of a step (i.e., binary) function, hence will present a transition zone instead of a sharp step and can assume a full range of values between 0 and 1.

Table 4 – 2nd-order regression equations for the various scenarios (note that in scenario 2a the term B should be always negative)

Scen.	Regression equations		
	RSI _{min} (R=2)	RSI _{min} (R=INF)	Type-I stability
1	RSI_Min =	RSI_Min =	Type-I-stability =
	+96.16309	+92.94200	+1.00
	+0.056401 * α	+0.20766 * α	
	-0.042298 * M	-0.031154 * M	
	-4.50262 * L	+3.05293 * L	
	-29.75976 * H	-32.94627 * H	
	+1.07202E-003 * α * M	+1.07202E-003 * α * M	
	+0.79497 * α * H	+0.79497 * α * H	
	-0.012849 * M * L	-0.012849 * M * L	
	+0.077568 * M * H	+0.077568 * M * H	
	-0.019657 * α ²	-0.019657 * α ²	
	-2.58571E-005 * M ²	-2.58571E-005 * M ²	
	(R ² =0.9969)		(R ² =1.0000)
2a	RSI_Min =	RSI_Min =	Type-I-stability =
	+109.03500	+108.76062	+1.14927
	-0.34654 * α	-0.21593 * α	+0.018358 * α
	-0.13195 * M	-0.12038 * M	+2.47835E-003 * m
	-2.73099 * L	+2.34224 * L	-0.26241 * L
	-21.78518 * H	-23.93316 * H	-0.17134 * H
	+1.46976 * B	+0.091648 * B	+0.35081 * B
	+2.81635E-003 * α * M	+2.81635E-003 * α * M	-2.55102E-005 * α * m
	+0.53414 * α * H	+0.53414 * α * H	+0.018235 * α * H
	-0.015324 * M * L	-0.015324 * M * L	+1.62527E-003 * m * L
	+0.093031 * M * H	+0.093031 * M * H	+2.05354E-003 * m * B
	+0.085746 * M * B	+0.085746 * M * B	+0.087634 * L * H
	-0.016959 * α ²	-0.016959 * α ²	-0.21851 * L * B
		-0.32828 * H * B	
		-4.58554E-004 * α ²	
		-5.39898E-006 * m ²	
		-0.078105 * L ²	
		-0.51808 * H ²	

Table 5 (Continued): 2nd-order regression equations for the various scenarios (note that in scenario 2a the term B should be always negative)

	(R ² =0.9774)		(R ² =0.6167)
2b	RSI_Min =	RSI_Min =	Type-I-stability =
	+105.29708	+110.09303	+0.81978
	-0.32254 * α	-0.25815 * α	+0.042989 * α
	-0.071522 * M	-0.11362 * M	+8.15055E-004 * m
	+0.35071 * L	-3.14617 * L	-0.34197 * L
	-21.25039 * H	-21.25039 * H	-0.15359 * H
	+0.96774 * B	-1.66796 * B	-0.33816 * B
	+2.95557E-003 * α * M	+2.95557E-003 * α * M	+1.41723E-005 * α * m
	+0.49877 * α * H	+0.49877 * α * H	+0.014692 * α * H
	+0.014289 * M * L	+0.014289 * M * L	+1.71888E-003 * m * L
	+0.085981 * M * H	+0.085981 * M * H	+5.26401E-004 * m * H
	-0.080963 * M * B	-0.080963 * M * B	-1.63705E-003 * m * B
	+1.12475 * L * B	+1.12475 * L * B	+0.099726 * L * H
	-0.016381 * α^2	-0.016381 * α^2	+0.18374 * L * B
-8.98567E-005 * M ²	-8.98567E-005 * M ²	+0.26060 * H * B	
		-8.11287E-004 * α^2	
		-8.23345E-006 * m ²	
		-0.45745 * H ²	
	(R ² =0.9724)		(R ² =0.5660)
3	RSI_Min =	RSI_Min =	Type-I-stability =
	+4.39722	-16.05782	-2.76190
	+4.73858 * α	+5.18251 * α	+0.19286 * α
	-0.049523 * M	-0.031955 * M	-2.38095E-003 * α^2
	-41.52679 * L	+9.09504 * L	
	+120.46558 * H	+141.58700 * H	
	-1.62050E-003 * α * M	-1.62050E-003 * α * M	
	-0.037083 * α * L	-0.037083 * α * L	
	-5.30990 * α * H	-5.30990 * α * H	
	-0.016360 * M * L	-0.016360 * M * L	
	-0.090118 * M * H	-0.090118 * M * H	
	-1.77679 * L * H	-1.77679 * L * H	
	-0.058157 * α^2	-0.058157 * α^2	
	+9.87011E-005 * M ²	+9.87011E-005 * M ²	
-0.29067 * L ²	-0.29067 * L ²		
-0.049603 * H ²	-0.049603 * H ²		
			(R ² =0.7222)

As can be observed, the determination coefficient (R^2) of RSI_{min} models is very high (greater than 0.9724), so they can be rightfully used for making preventive predictions about the Type-II equilibrium of a tractor equipped with an implement. Due to the presence, in real situations, of some not-quantifiable effects that can worsen the vehicle's equilibrium (e.g., the lateral deformations of the tyres, the soil compaction under the most loaded tyres, the local presence of ruggedness/depressions of the ground), it can be appropriate to evidence, for the RSI_{min} , also the threshold of 5 other than the only threshold corresponding to 0 (i.e., incipient overturning). Concerning the prediction of Type-I equilibrium, due to the smoothing of the binary function built from the output values given by the simulator, previously discussed, the obtained determination coefficients are necessary lower than the determination coefficients of the RSI_{min} models. Moreover,

for the same reasons explained above (not-quantifiable effects in real situations), a vehicle (tractor + implement) should be considered safe from type-I rollovers only if the Type-I stability function has a value greater than 0.7 (rather than greater than 0.5). Therefore, it is necessary to give the values of the Type-I-stability function with one decimal.

1.7 Equilibrium maps

The equations reported above can be graphically represented by evidencing the areas in which the vehicle is stable/unstable (positive/negative values for the RSI_{min} , values greater/lower than 0.7 for the Type-I stability). It is therefore possible to generate some graphs by keeping constant (and equal to some representative values) all but two of the inquired independent variables (α , R, M, L, H, B; Figure 4).

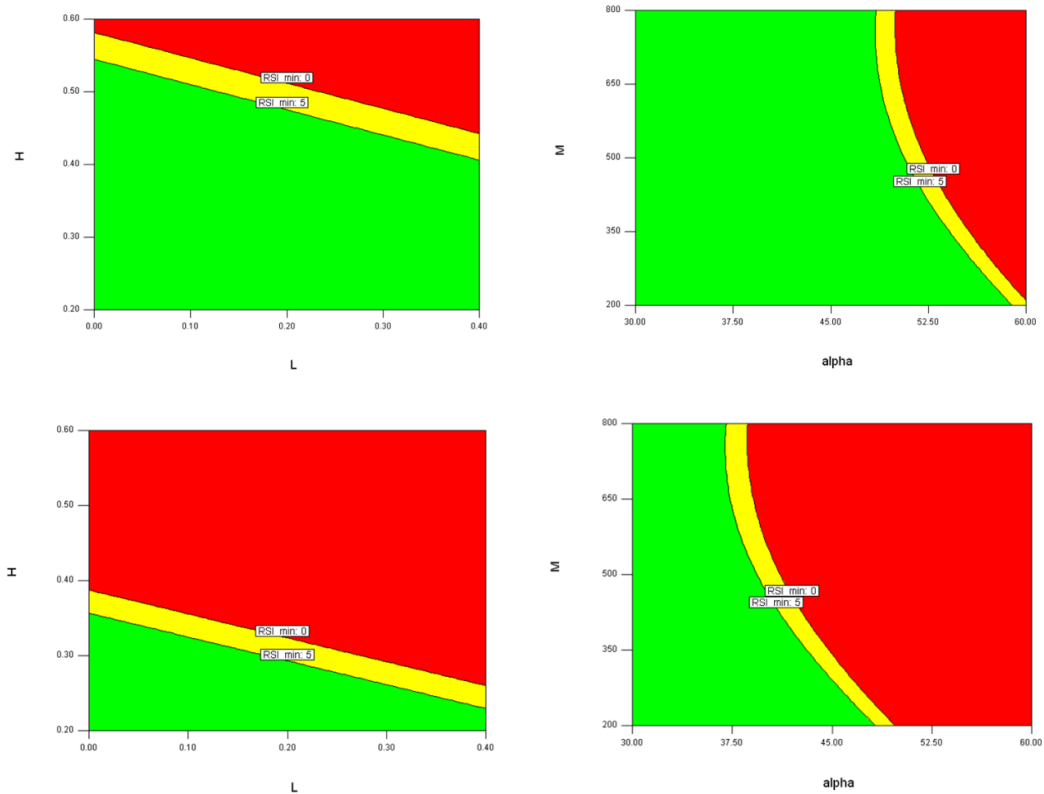

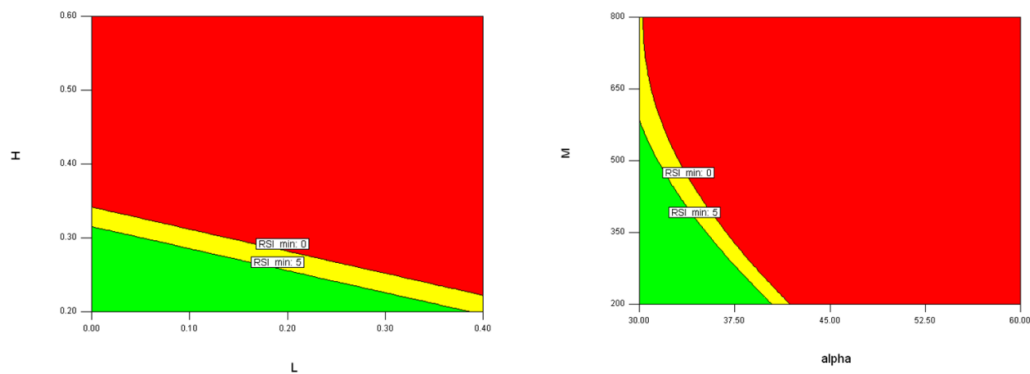

Figure 4 – Equilibrium maps for the RSI_{min} showing the vehicle's safe (green; $RSI_{min} > 5$), near-critical (yellow; $0 < RSI_{min} < 5$) and unsafe zones (red; $RSI_{min} < 0$) of an implement positioned directly on the tractor's rear end; on the left, it is inquired the effect of the position of the CoG (x axis: L; y axis: H) of an implement having a mass $M=200$, 500 and 800 kg respectively from the top to the bottom ($\alpha=45^\circ$, $R=2$ m); on the right, it is inquired the effect of the ground slope α (x axis) and of the mass M (y axis) of an implement having $H=0.2$, 0.4 and 0.6 m respectively from the top to the bottom ($L=0.2$ m, $R=2$ m). The equilibrium maps concerning the Type-I stability are not reported because not interesting in this case (all green, i.e. the front and rear parts of the tractor are Type-I stable; see Table 7).

1.8 Use of the regression equations/equilibrium maps

Thanks to the regression equations, we verified the possibility to use several different commercial implements on this tractor (Table 6, Table 7); their dimensions, CoG positions and masses were taken from the respective catalogues. The hydraulic-driven implements were chosen by matching the minimum power requirements, indicated by the manufacturers for operating them, with the maximum available power of the tractor under study (26 kW at 3600 rpm).

Table 6 – Possible implements to be mounted frontally (scenarios: 1, 2a, 2b) on the tractor and assessment of the stability of the whole vehicle (tractor + implement); two numbers will be reported for lateral implements: the first/second one refers to an implement located at the external/internal side of the turn (i.e. with B negative or positive, respectively); H is the height of the implement's CoG from the ground, L is the distance implement's CoG - front part of the tractor (positive because in the same direction of the y axis), B is the distance CoG - tractor's longitudinal axis (positive if in the same direction of the x axis)

Implement	M (kg)	H (m)	L (m)	B (m)	Minimum RSI				Type-I st.	
					$\alpha=30^\circ$		$\alpha=45^\circ$		$\alpha=30^\circ$	$\alpha=45^\circ$
					R=2	R=INF	R=2	R=INF	R=2 or INF	
Front shredder/ fodder cutter	165	0.280	0.500	0	76	82	61	69	1.0	1.0
	190	0.280	0.500	0	76	83	61	70	1.0	1.0
	230	0.280	0.500	0	76	83	62	71	1.0	1.0

Front vine-shoot shredder	250	0.280	0.500	0	76	83	62	71	1.0	1.0
	275	0.280	0.500	0	76	83	62	72	1.0	1.0
	300	0.280	0.500	0	75	83	62	72	1.0	1.0
	320	0.280	0.500	0	75	83	62	73	1.0	1.0
	335	0.280	0.500	0	75	83	63	73	1.0	1.0
Lateral shredder/ fodder cutter	245	0.280	1.050	±1.05	46/69	59/59	34/59	49/50	0.9/1.0	0.7/0.7
	265	0.280	1.050	±1.15	41/66	54/55	30/56	45/46	0.8/0.9	0.6/0.6
	285	0.280	1.050	±1.25	36/62	49/50	26/54	41/42	0.7/0.8	0.5/0.5
Shoot remover	55	0.280	0.500	±0.50	76/80	83/82	56/61	65/64	1.0/1.0	1.0/1.0
Bilateral shoot remover	110	0.280	0.500	±1.00	66/76	75/74	49/60	59/59	1.0/1.0	0.8/0.9
Sickle bar	140	1.260	0.500	±0.50	77/85	82/83	68/77	76/76	1.0/1.0	1.0/1.0
Double sickle bar	180	1.260	0.500	±0.50	77/88	84/84	71/82	79/79	1.0/1.0	1.0/1.0

Table 7 – Possible implements to be mounted on the rear end of the tractor (scenario 3) and assessment of the stability of the resulting vehicle (tractor + implement); the significance of M and H is the same as above, L is instead the distance of the implement’s CoG from the rear axle (positive: the implement’s CoG is behind the rear axle, i.e. opposite the joint)

Implement	Load capacity (m ³)	M (kg)	H (m)	L (m)	Minimum RSI				Type-I st.	
					$\alpha=30^\circ$		$\alpha=45^\circ$		$\alpha=30^\circ$	$\alpha=45^\circ$
					R=2	R=INF	R=2	R=INF	R=2 or INF	
Sprayer equipment (*)	0.200	290	0.338	0.295	52	72	31	57	0.9	1.0
Dumper carrying apples(*) (**)	0.482	328	0.430	0.243	47	67	19	45	0.9	1.0
Dumper carrying sand (*)	0.482	770	0.430	0.243	54	82	26	60	0.9	1.0

* Each implement was considered at its maximum load capacity (i.e., the sprayer was supposed to be filled up with water, the dumper with apples or sand) and to be symmetrical with respect to the tractor’s longitudinal axis. ** We consider: 800 kg/m³ as average density for the apples, 0.85 as solid/void ratio.

Observing the values of minimum RSI in Table 6 and Table 7, it is possible to notice that generally this index decreases, as expectable:

- with the increase of the implement’s mass M, which has the effect to move the global CoG of the vehicle towards the implement’s CoG;
- with the increase of the distance L (between the implement’s CoG and the front part of the tractor or, in scenario 3, between the implement’s CoG and the rear axle of the tractor);
- with the increase of the distance B (between the implement’s CoG and the tractor’s longitudinal axis), shifting laterally the global CoG from the longitudinal axis;
- with the increase of the distance H (height of the implement’s CoG from the ground), having the effect to lift up the global CoG.

As a consequence, for example, the implements to be mounted in the front part of the tractor have a stabilizing effect on the vehicle, due to the very low height of

their centres of gravity; vice versa for the implements to be mounted on the tractor's rear end.

According to Eq. 1, as the minimum RSI associated with the listed implements is always greater than zero (and greater than 5), Type-II rollover will never occur on a ground with the assumed slopes.

Looking at the values of the Type-I stability function, overturn can occur when turning on a 30°-slope ground with a 285-kg lateral shredder at the external side of the turn and when using a lateral shredder with a mass greater than 245 kg on a 45°-slope ground, whichever the position of the implement's CoG (external/internal side of the turn). Therefore, a possible user must absolutely not use that implement in the described conditions. The same verification can also be done by using the equilibrium maps drawn with $H=0.28$ m and $L=1.05$ m (Figure 5). If $\alpha=45^\circ$, $R=2$ m, it is necessary to place the points ($B_1=-1.05$ m, $M_1=245$ kg), ($B_2=-1.15$ m, $M_2=265$ kg) and ($B_3=-1.25$ m, $M_3=285$ kg) within the graphs and observe the colour of the background in correspondence to them.

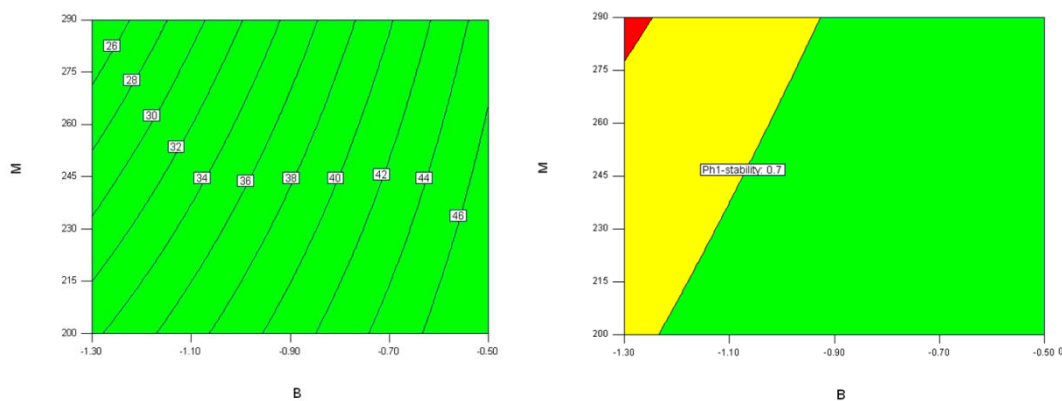

Figure 5 – Equilibrium maps for the RSI_{\min} (left) and Type-I stability (right) for a lateral shredder (with: $L=0.2$ m, $H=0.28$ m, $\alpha=45^\circ$, $R=2$ m) drawn with respect to the distance B of the implement's CoG to tractor's longitudinal axis (x axis) and with respect to the mass M (y axis); different contours have been plotted in the RSI_{\min} equilibrium map to evidence how the index increases (from top-left to down-right)

Conclusion

This work shows a methodological approach for evaluating a priori the stability of agricultural vehicles equipped with different mounted implements and operating on a sloping ground. In particular, this study has focussed the attention on a very particular but promising type of farm tractor, i.e. a 4-wheel drive articulated tractor, very agile and having many points of innovation.

The approach uses a Matlab simulator in its first phase and, subsequently, the RSM technique to evaluate the coefficients of a set of regression equations able to account for the shifting of the centre of gravity of the whole vehicle when it is equipped with implements having known dimensions and masses. These regression

equations can be implemented in a simple spreadsheet and can give reliable punctual numeric estimations of the minimum value of the RSI and the existence of a Type-I equilibrium without any need to run the Matlab simulator or know any detail about the model used in it.

The same equations can also be used to generate many intuitive graphs, named “equilibrium maps”, which can be used to verify graphically, hence quickly, the same parameters (RSI_{min} and Type-I equilibrium). Those graphs are similar somehow to the graphs already adopted by the manufacturers of cranes or other yard machines (e.g., excavating machines) which can have possible problems of rollover during their operation (due to the different configurations assumed by their frame): each of these machines is provided with an abacus giving clear safety limits to the extension of the adjustable jib (or of the power shovel for an excavator) as a function of the lifted payload. In the same way, the present study proposes to build similar “*stability graphs*”, here called “*equilibrium maps*” (eventually given in the form of precompiled tables), also for agricultural machines operating on sloping grounds, thus integrating the safety equipment of that vehicle. This tool (maybe depicted on the dashboard/in the cabin) can be used, for example, when the driver of a tractor has the need to purchase a new implement or simply to connect an existing implement to his machine: through an equilibrium map, he can know in advance if his vehicle will be stable or not in his field (and acting accordingly, e.g. adjusting the position of the implement or limiting the payload if dealing of a dumper).

The proposed approach and its main outcomes (the regression equations and the equilibrium maps) can give an effective contribution to the preventive safety of the tractor driver, so our proposal is to integrate it in the homologation procedures for every vehicle and to include the resulting documentation within the tractor logbook.

Acknowledgements. This work was developed within the “*TrabtGUT*” research project of the Free University of Bozen-Bolzano.

References

- [1] M. Cecchini, F. Cossio, A. Marucci, D. Monarca, A. Colantoni, M. Petrelli, and E. Allegrini, Survey on the status of enforcement of European directives on health and safety at work in some Italian farms, *J. Food, Agric. Environ*, **11** (2013), no. 3&4, 595-600.
- [2] D. Monarca, M. Cecchini, M. Guerrieri, M. Santi, R. Bedini, and A. Colantoni, *Safety and health of workers: exposure to dust, noise and vibrations*, *ISHS Acta Horticulturae 845: VII International Congress on Hazelnut*, (2009), no. 845, 437-442.
<http://dx.doi.org/10.17660/actahortic.2009.845.68>

- [3] S. R. S. Cividino, R. Gubiani, G. Pergher, D. Dell'Antonia, and E. Maroncelli, Accident investigation related to the use of chainsaw, *J. Agric. Eng.*, **44** (2013).
- [4] S. R. S. Cividino, O. Malev, M. Lacovig, G. Pergher, D. Dell'Antonia, R. Gubiani, and M. Vello, BiogasAgriAtex, new methods of risk assessment explosion on biogas plants, *Appl. Math. Sci.*, **8** (2014), no.132, 6599–6619. <http://dx.doi.org/10.12988/ams.2014.46449>
- [5] F. Mazzetto, M. Bietresato, and R. Vidoni, Development of a dynamic stability simulator for articulated and conventional tractors useful for real-time safety devices, *Appl. Mech. Mater.*, **394** (2013), 546-553. <http://dx.doi.org/10.4028/www.scientific.net/amm.394.546>
- [6] A. G. M. Hunter, A review of research into machine stability on slopes, *Saf. Sci.*, **16** (1993), no. 3-4, 325-339. [http://dx.doi.org/10.1016/0925-7535\(93\)90052-f](http://dx.doi.org/10.1016/0925-7535(93)90052-f)
- [7] I. Gravalos, T. Gialamas, S. Loutridis, D. Moshou, D. Kateris, P. Xyradakis, and Z. Tsiropoulos, An experimental study on the impact of the rear track width on the stability of agricultural tractors using a test bench, *J. Terramechanics*, **48** (2011), no.4, 319-323. <http://dx.doi.org/10.1016/j.jterra.2011.04.003>
- [8] G. Previati, M. Gobbi, and G. Mastinu, Mathematical models for farm tractor rollover prediction, *Int. J. Veh. Des.*, **64** (2014), 280. <http://dx.doi.org/10.1504/ijvd.2014.058486>
- [9] R. Vidoni, M. Bietresato, A. Gasparetto, and F. Mazzetto, Evaluation and stability comparison of different vehicle configurations for robotic agricultural operations on side-slopes, *Biosyst. Eng.*, **129** (2015), 197-211. <http://dx.doi.org/10.1016/j.biosystemseng.2014.10.003>
- [10] F. Mazzetto, M. Bietresato, A. Gasparetto, and R. Vidoni, Simulated stability tests of a small articulated tractor designed for extreme-sloped vineyards, *J. Agric. Eng.* **XLIV**, (2013), 663–668.
- [11] D. Longo, A. Pennisi, R. Bonsignore, G. Schillaci, and G. Muscato, A small autonomous electrical vehicle as partner for heroic viticulture, *ISHS Acta Horticulturae 978: I International Workshop on Vineyard Mechanization and Grape and Wine Quality*, (2013), 391-398. <http://dx.doi.org/10.17660/actahortic.2013.978.45>

- [12] A. L. Guzzomi, V. Rondelli, A. Guarnieri, G. Molari, and P. G. Molari, Available energy during the rollover of narrow-track wheeled agricultural tractors, *Biosyst. Eng.*, **104** (2009), no. 3, 318-323.
<http://dx.doi.org/10.1016/j.biosystemseng.2009.07.005>
- [13] A. L. Guzzomi, A revised kineto-static model for Phase I tractor rollover, *Biosyst. Eng.*, **113** (2012), no. 1, 65-75.
<http://dx.doi.org/10.1016/j.biosystemseng.2012.06.007>
- [14] V. Baker and A. L. Guzzomi, A model and comparison of 4-wheel-drive fixed-chassis tractor rollover during Phase I, *Biosyst. Eng.*, **116** (2013), no. 2, 179-189. <http://dx.doi.org/10.1016/j.biosystemseng.2013.07.016>
- [15] I. Ahmadi, Dynamics of tractor lateral overturn on slopes under the influence of position disturbances (model development), *J. Terramechanics*, **48** (2011), no. 5, 339-346.
<http://dx.doi.org/10.1016/j.jterra.2011.07.001>
- [16] A. Pazooki, S. Rakheja, and D. Cao, Modeling and validation of off-road vehicle ride dynamics, *Mech. Syst. Signal Process.*, **28** (2012), 679-695.
<http://dx.doi.org/10.1016/j.ymsp.2011.11.006>
- [17] B. Ji-hua, L. Jin-liang, and Y. Yan, Lateral stability analysis of the tractor/full trailer combination vehicle, in *2011 Int. Conf. Electr. Inf. Control Eng.*, (2011). <http://dx.doi.org/10.1109/iceice.2011.5777033>
- [18] M. Karkee and B. L. Steward, Local and global sensitivity analysis of a tractor and single axle grain cart dynamic system model, *Biosyst. Eng.*, **106** (2010), no. 4, 352-366.
<http://dx.doi.org/10.1016/j.biosystemseng.2010.04.006>
- [19] S. Popescu and N. Sutru, Contributions to the study of the dynamics of agricultural tractors equipped with front-end loader and rear forklift loader, in *Eng. Rural Dev. - Int. Sci. Con.*, (Jelgava, Latvia, 2009).
- [20] F. Mazzetto, R. Gallo, R. Vidoni, and C. Bisaglia, Development and characterization tests of a small hydraulic-powered tractor prototype for use in extreme sloped vineyards, *ISHS Acta Horticulturae 978: I International Workshop on Vineyard Mechanization and Grape and Wine Quality*, 369-376, (2013). <http://dx.doi.org/10.17660/actahortic.2013.978.42>
- [21] F. Mazzetto, R. Gallo, R. Vidoni, C. Bisaglia, and A. Calcante, Designing and testing a new small tractor prototype for the mechanisation of terraced-vineyard farming systems in South-Tyrol, in *Int. Conf. RAGUSA*

- SHWA 2012 - "Safety Heal. Welf. Agric. Agro-food Syst.*, A. Conti, S. Failla, and D. Camillieri, Eds., (Elle Due, Ragusa, Italy, 2012).
- [22] F. Mazzetto, M. Bietresato, C. Bisaglia, R. Vidoni, and J. Weger, Proposal of a small-size reversible articulated tractor for safe operating in very steep hillsides, in *Int. Comm. Agric. Biol. Eng. Sect. V. CIOSTA XXXV Conf. "From Eff. to Intell. Agric. For.*, (CIOSTA, Billund, Denmark, 2013).
- [23] M. G. Yisa, H. Terao, N. Noguchi, and M. Kubota, Stability criteria for tractor-implement operation on slopes, *J. Terramechanics*, **35** (1998), no.1 1-19. [http://dx.doi.org/10.1016/s0022-4898\(98\)00008-1](http://dx.doi.org/10.1016/s0022-4898(98)00008-1)
- [24] J. Liu and P. D. Ayers, Control Strategies and System for Tractor Protective Structure Deployment, in *1999 Summer Conf. Natl. Inst. Farm Saf.*, (Ocean City, Maryland, USA, 1999).
- [25] R. Huang, J. Zhan, and J. Wu, Effect of Differential Modeling on Handling and Stability, in *Proc. FISITA 2012 World Automot. Congr.*, **198** (2012), SAE-China and FISITA, Ed., (Beijing, China, 2012). http://dx.doi.org/10.1007/978-3-642-33795-6_36
- [26] H. Silleli, M. a. Dayıođlu, A. Gültekin, K. Ekmekçi, M. A. Yıldız, E. Akay, and G. Saranlı, Anchor mechanism to increase the operator clearance zone on narrow-track wheeled agricultural tractors: Prototype and first tests, *Biosyst. Eng.*, **97** (2007), no. 2, 153-161. <http://dx.doi.org/10.1016/j.biosystemseng.2007.02.016>
- [27] B. Mashadi and H. Nasrolahi, Automatic control of a modified tractor to work on steep side slopes, *J. Terramechanics*, **46** (2009), no. 6, 299-311. <http://dx.doi.org/10.1016/j.jterra.2009.08.006>
- [28] G. Genta, *Motor Vehicle Dynamics: Modeling and Simulation - Series on Advances in Mathematics for Applied Sciences*, World Scientific Publishing Co Pte Ltd, Singapore, 1997. <http://dx.doi.org/10.1142/3329>
- [29] M. Bietresato, S. Pavan, G. Cozzi, and L. Sartori, A numerical approach for evaluating and properly setting self-propelled forage harvesters, *Trans. ASABE*, **56** (2013), 5-14. <http://dx.doi.org/10.13031/2013.42580>
- [30] M. Bietresato and L. Sartori, Technical aspects concerning the detection of animal waste nutrient content via its electrical characteristics, *Bioresour. Technol.*, **132** (2013), 127-136. <http://dx.doi.org/10.1016/j.biortech.2012.12.184>

- [31] N. Maheshwari, C. Balaji, and A. Ramesh, A nonlinear regression based multi-objective optimization of parameters based on experimental data from an IC engine fueled with biodiesel blends, *Biomass and Bioenergy*, **35** (2011), no. 5, 2171-2183. <http://dx.doi.org/10.1016/j.biombioe.2011.02.031>
- [32] M. Bietresato, A. Calcante, and F. Mazzetto, A neural network approach for indirectly estimating farm tractors engine performances, *Fuel*, **143** (2015), 144-154. <http://dx.doi.org/10.1016/j.fuel.2014.11.019>

Received: March 30, 2015; Published: October 16, 2015